

9.2 DIMENSIONS AND TECHNICAL SPECIFICATIONS

SL 070

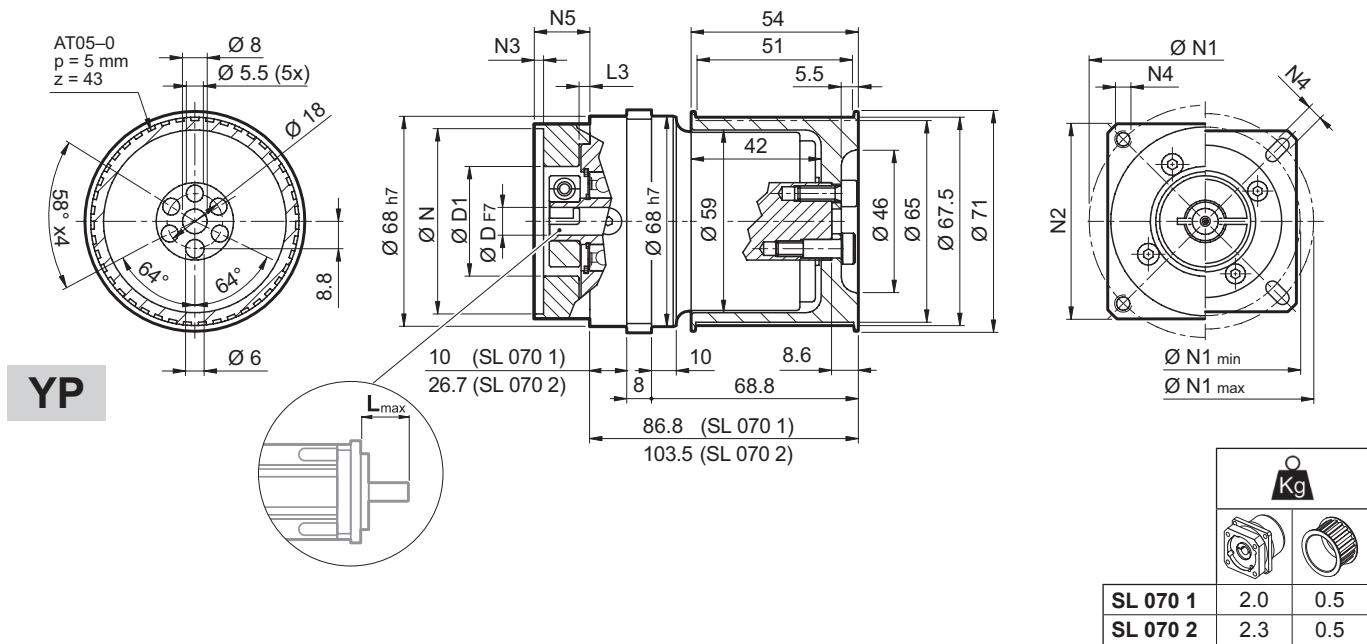

TS

	D										N	N1		N2	N3	N4	N5	L <sub>max</sub>
	6.35	7	8	9	9.52	10	11	12	12.7	14		min	max					
25AH	6.35	7	8	9	9.52	-	-	-	-	-	25	39	56					
26AH	6.35	7	8	9	9.52	-	-	-	-	-	26	39	56					
28AH	6.35	7	8	9	9.52	-	-	-	-	-	28	39	56					
30AH	6.35	7	8	9	9.52	-	-	-	-	-	30	39	56					
32AH	6.35	7	8	9	9.52	-	-	-	-	-	32	39	56	65	3.5	4.5	25	25
34AH	6.35	7	8	9	9.52	-	-	-	-	-	34	40	56					
36AH	6.35	7	8	9	9.52	-	-	-	-	-	36	42	56					
39AH	6.35	7	8	9	9.52	-	-	-	-	-	39	45	56					
40AH	6.35	7	8	9	9.52	-	-	-	-	-	40	46	56					
38B	6.35	7	8	9	9.52	10	11	12	12.7	-	38.1	66.6	60	3	M4x10	18	25	
40B	6.35	7	8	9	9.52	10	11	12	12.7	-	40	63	60	3	M4x10	18	25	
50A	6.35	7	8	9	9.52	10	11	12	12.7	-	50	60	60	3	M4x10	18	25	
50B	6.35	7	8	9	9.52	10	11	12	12.7	14	50	65	60	3	M5x12	23	30	
50BH	6.35	7	8	9	9.52	10	11	12	12.7	14	50	65	65	3	5.5	25	32	
50C	6.35	7	8	9	9.52	10	11	12	12.7	14	50	70	60	3	M4x10	23	30	
55MH	6.35	7	8	9	9.52	10	11	12	12.7	-	55	80	65	2	5.5	16	23	
60A	6.35	7	8	9	9.52	10	11	12	12.7	-	60	75	65	3	M5x12	18	25	
60A1	6.35	7	8	9	9.52	10	11	12	12.7	14	60	75	65	3	M5x12	23	30	
60B	6.35	7	8	9	9.52	10	11	12	12.7	14	60	85	75	3	M5x12	23	30	
60C	6.35	7	8	9	9.52	10	11	12	12.7	14	60	90	75	3	M5x12	23	30	
70A	6.35	7	8	9	9.52	10	11	12	12.7	14	70	85	75	3	M6x15	23	30	
70B	6.35	7	8	9	9.52	10	11	12	12.7	14	70	90	75	5	M5x12	23	30	
73A	6.35	7	8	9	9.52	10	11	12	12.7	14	73	98.4	85	3	M5x12	25	32	
80A	6.35	7	8	9	9.52	10	11	12	12.7	14	80	100	85	3	M6x15	23	30	

Please contact us for different motor adapters and input shaft bore.

# SL 070

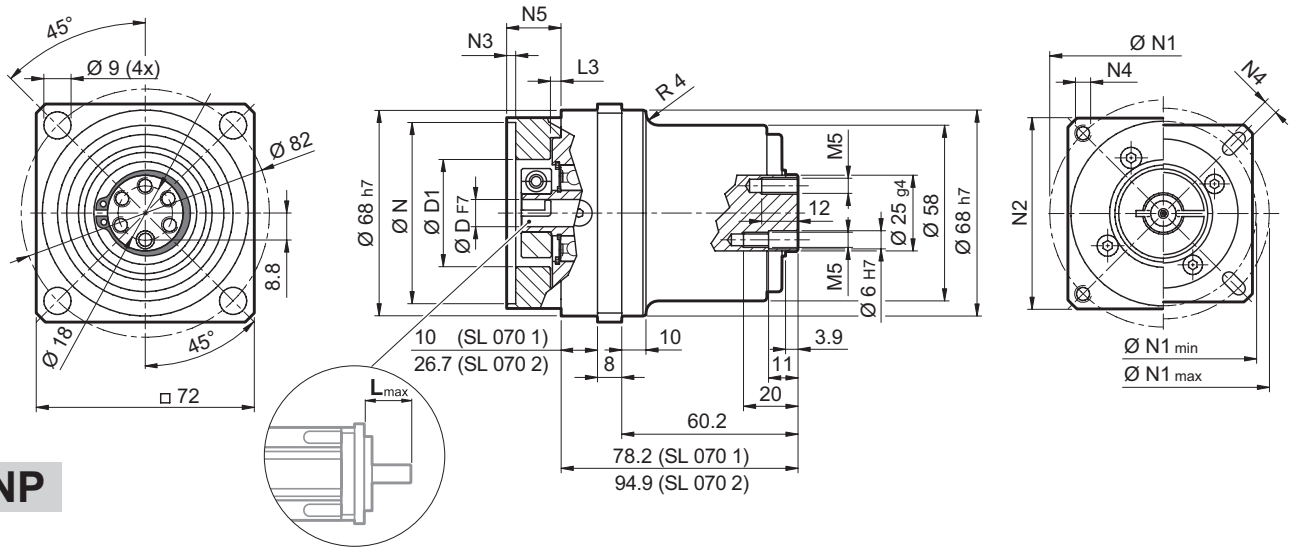

**NP**

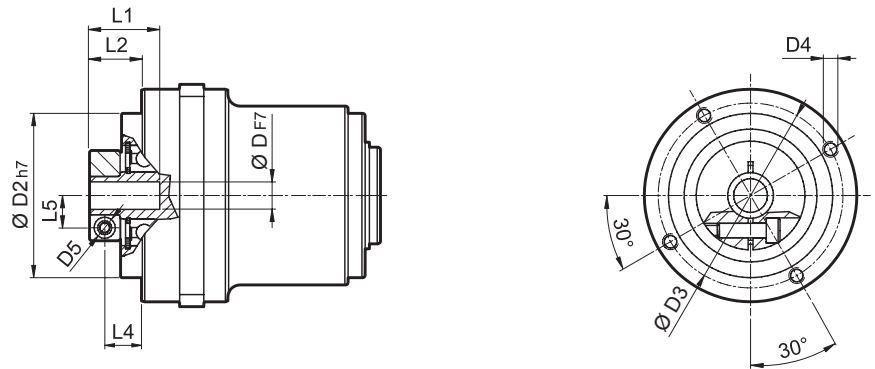

**FM**

D				D1	D2	D3	D4	D5	L1	L2	L3	L4	L5
6.35	7			32.5	50	42.5	M4x8	M4	21.7	13.2	3	8.2	8
8	9	9.52	10	32.5	50	42.5	M4x8	M4	21.7	13.2	3	8.2	9
11	12	12.7		35.5	50	42.5	M4x8	M4	22	13.5	3	8.5	11
14				35.5	50	42.5	M4x8	M4	25	17	3	10.2	11.5

TS

i	M <sub>n2</sub> [Nm]	M <sub>a2</sub> [Nm]	M <sub>p2</sub> [Nm]	n <sub>1</sub> [min <sup>-1</sup> ]	n <sub>1 max</sub> [min <sup>-1</sup> ]	φ <sub>S</sub> [arcmin]	φ <sub>R</sub> [arcmin]	C <sub>t</sub> [ $\frac{Nm}{arcmin}$ ]	R <sub>2 max</sub> * [N]	A <sub>2 max</sub> [N]	η %	J <sub>G</sub> [kgcm <sup>2</sup> ]		3.86
												D		
SL 070 1_3	18	30	60	3300	4000	12'	6'	6.5	3500	1600	97	6 ... 9.52	11 ... 14	
SL 070 1_4	25	35	70	3500	5000	12'	6'	6.5	3500	1600	97	0.09	0.11	
SL 070 1_5	25	35	70	3500	5000	12'	6'	6.5	3500	1600	97	0.07	0.09	
SL 070 1_7	25	35	70	3500	5000	12'	6'	6.5	3500	1600	97	0.05	0.07	
SL 070 1_10	18	30	60	4000	6000	12'	6'	6.5	3500	1600	97	0.04	0.06	
SL 070 2_9	18	30	60	3300	4000	15'	8'	6	3500	1600	94	0.11	0.13	
SL 070 2_12	25	35	70	3300	4000	15'	8'	6	3500	1600	94	0.10	0.13	
SL 070 2_15	25	35	70	3300	4000	15'	8'	6	3500	1600	94	0.10	0.12	
SL 070 2_16	25	35	70	3500	5000	15'	8'	6	3500	1600	94	0.07	0.09	
SL 070 2_20	25	35	70	3500	5000	15'	8'	6	3500	1600	94	0.06	0.08	
SL 070 2_25	25	35	70	3500	5000	15'	8'	6	3500	1600	94	0.06	0.08	
SL 070 2_28	25	35	70	4000	6000	15'	8'	6	3500	1600	94	0.05	0.07	
SL 070 2_30	18	30	60	4000	6000	15'	8'	6	3500	1600	94	0.04	0.06	
SL 070 2_35	25	35	70	4000	6000	15'	8'	6	3500	1600	94	0.05	0.07	
SL 070 2_40	25	35	70	4000	6000	15'	8'	6	3500	1600	94	0.04	0.06	
SL 070 2_50	25	35	70	4000	6000	15'	8'	6	3500	1600	94	0.04	0.06	
SL 070 2_70	25	35	70	4000	6000	15'	8'	6	3500	1600	94	0.04	0.06	
SL 070 2_100	18	30	60	4000	6000	15'	8'	6	3500	1600	94	0.04	0.06	

\* Applies for timing belt application

# SL 090

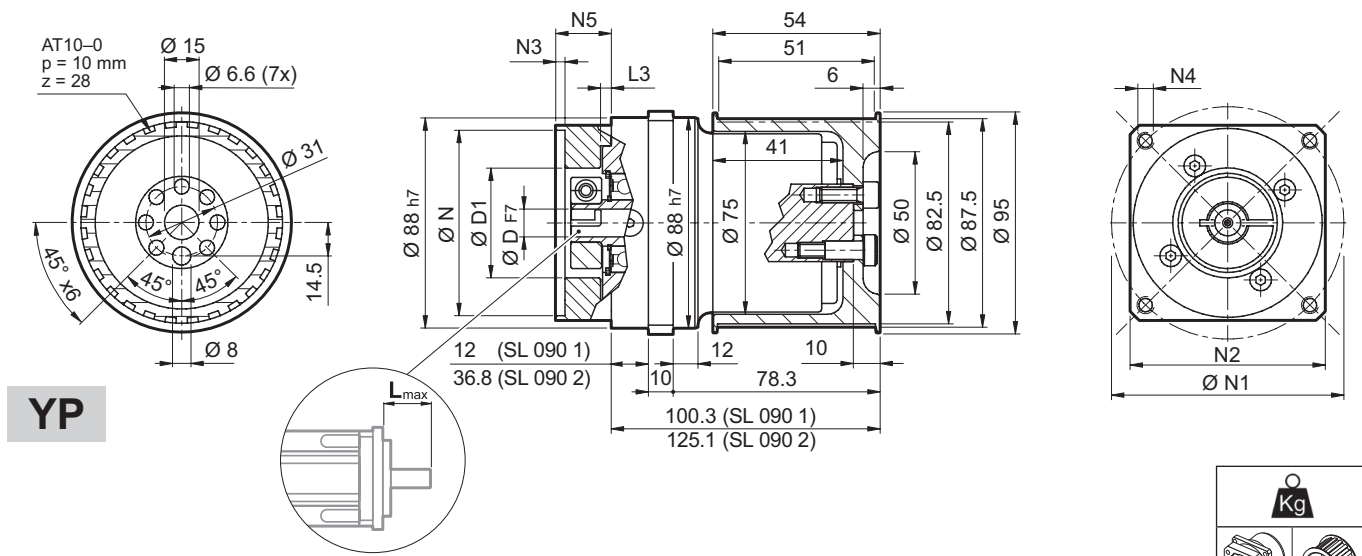

<b>SL 090 1</b>	3.6	0.8
<b>SL 090 2</b>	4.7	0.8

TS

												N	N1	N2	N3	N4	N5	L <sub>max</sub>
40B1	9	9.52	11	12	12.7	14	-	-	-	-	-	40	63	80	4	M4x10	34	40
45A	9	9.52	11	12	12.7	-	-	-	-	-	-	45	63	80	4	M4x10	34	40
50B1	9	9.52	11	12	12.7	14	-	-	-	-	-	50	65	80	4	M5x16	34	40
50BH1	9	9.52	11	12	12.7	14	-	-	-	-	-	50	65	80	4	5.5	34	40
50C1	9	9.52	11	12	12.7	14	-	-	-	-	-	50	70	80	4	M4x10	34	40
50D	9	9.52	11	12	12.7	14	-	-	-	-	-	50	95	80	4	M6x10	34	40
55A	9	9.52	11	12	12.7	14	15.875	16	17	19	19.05	55.5	125.7	105	4	M6x16	34	40
60A2	9	9.52	11	12	12.7	14	-	-	-	-	-	60	75	80	4	M5x16	34	40
60AH2	9	9.52	11	12	12.7	14	-	-	-	-	-	60	75	90	4	5.5	34	40
60B1	9	9.52	11	12	12.7	14	15.875	16	-	-	-	60	85	80	4	M5x16	34	40
60C1	9	9.52	11	12	12.7	14	15.875	16	-	-	-	60	90	80	4	M5x16	34	40
70A1	9	9.52	11	12	12.7	14	15.875	16	17	19	19.05	70	85	80	4	M6x20	34	40
70AH1	9	9.52	11	12	12.7	14	15.875	16	17	19	19.05	70	85	90	4	6.5	34	40
70B1	9	9.52	11	12	12.7	14	15.875	16	17	19	19.05	70	90	80	4	M5x16	34	40
73A1	9	9.52	11	12	12.7	14	-	-	-	-	-	73	98.4	85	4	M5x16	34	40
80A1	9	9.52	11	12	12.7	14	15.875	16	17	19	19.05	80	100	90	4	M6x16	34	40
95A	9	9.52	11	12	12.7	14	15.875	16	17	19	19.05	95	115	100	4	M8x20	34	40
95B	9	9.52	11	12	12.7	14	15.875	16	17	19	19.05	95	130	115	4	M8x20	34	40
110A	9	9.52	11	12	12.7	14	15.875	16	17	19	19.05	110	130	115	4	M8x20	34	40
110B	9	9.52	11	12	12.7	14	15.875	16	17	19	19.05	110	145	120	6.5	M8x20	44	50
110B1	9	9.52	11	12	12.7	14	15.875	16	17	19	19.05	110	145	120	6.5	M8x20	54	60

Please contact us for different motor adapters and input shaft bore.

# SL 090

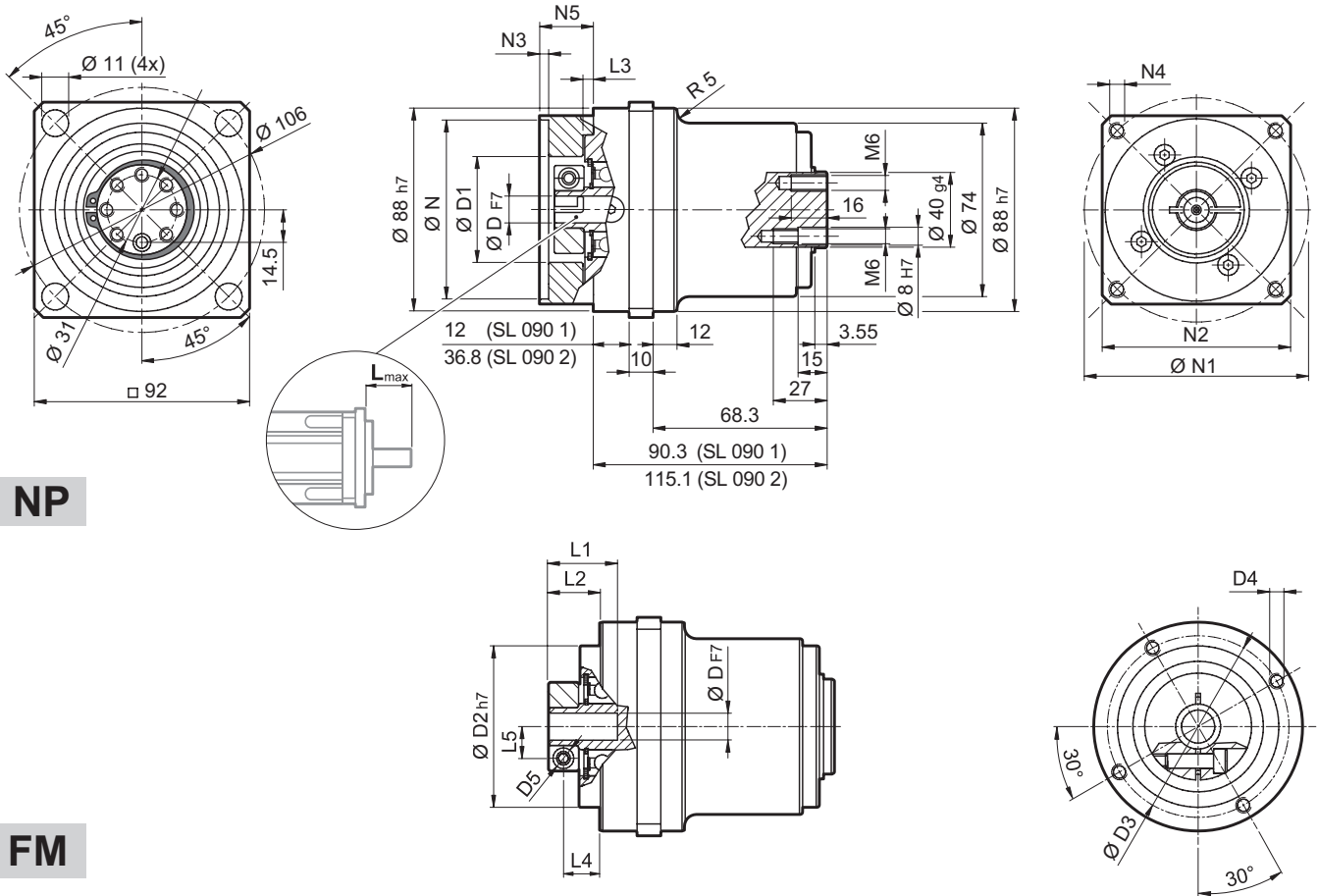

**NP**

**FM**

D		D1	D2	D3	D4	D5	L1	L2	L3	L4	L5
9	9.52	38	68	76.5	M6x10	M6	34	26.8	9.5	18.8	10.5
11	12	52	68	76.5	M6x10	M6	34	26.8	9.5	18.8	12.5
14	15.875	48	68	76.5	M6x10	M6	34	26.8	9.5	18.8	14.5
19	19.05	51	68	76.5	M6x10	M6	34	26.8	9.5	18.8	16.5

i	M <sub>n2</sub> [Nm]	M <sub>a2</sub> [Nm]	M <sub>p2</sub> [Nm]	n <sub>1</sub> [min <sup>-1</sup> ]	n <sub>1 max</sub> [min <sup>-1</sup> ]	φ <sub>S</sub> [arcmin]	φ <sub>R</sub> [arcmin]	C <sub>t</sub> [ $\frac{Nm}{arcmin}$ ]	R <sub>2 max</sub> * [N]	A <sub>2 max</sub> [N]	η %	J <sub>G</sub> [kgcm <sup>2</sup> ]		10.95
												D	D	
SL 090 1_3	37	70	150	2900	3500	12'	6'	12	4500	2000	97	0.72	0.81	10.95
SL 090 1_4	43	80	160	3100	4500	12'	6'	12	4500	2000	97	0.49	0.58	
SL 090 1_5	43	80	160	3200	4500	12'	6'	12	4500	2000	97	0.39	0.48	
SL 090 1_7	43	80	160	4000	6000	12'	6'	12	4500	2000	97	0.31	0.40	
SL 090 1_10	37	70	150	4000	6000	12'	6'	12	4500	2000	97	0.27	0.35	
SL 090 2_9	37	70	150	2900	3500	15'	8'	11.5	4500	2000	94	0.47	0.61	
SL 090 2_12	43	80	160	2900	3500	15'	8'	11.5	4500	2000	94	0.44	0.58	
SL 090 2_15	43	80	160	2900	3500	15'	8'	11.5	4500	2000	94	0.43	0.57	
SL 090 2_16	43	80	160	3100	4500	15'	8'	11.5	4500	2000	94	0.31	0.45	
SL 090 2_20	43	80	160	3200	4500	15'	8'	11.5	4500	2000	94	0.26	0.40	
SL 090 2_25	43	80	160	3200	4500	15'	8'	11.5	4500	2000	94	0.26	0.40	
SL 090 2_28	43	80	160	4000	6000	15'	8'	11.5	4500	2000	94	0.22	0.36	
SL 090 2_30	37	70	150	4000	6000	15'	8'	11.5	4500	2000	94	0.20	0.34	
SL 090 2_35	43	80	160	4000	6000	15'	8'	11.5	4500	2000	94	0.22	0.36	
SL 090 2_40	43	80	160	4000	6000	15'	8'	11.5	4500	2000	94	0.20	0.34	
SL 090 2_50	43	80	160	4000	6000	15'	8'	11.5	4500	2000	94	0.20	0.34	
SL 090 2_70	43	80	160	4000	6000	15'	8'	11.5	4500	2000	94	0.20	0.34	
SL 090 2_100	37	70	150	4000	6000	15'	8'	11.5	4500	2000	94	0.19	0.34	

\* Applies for timing belt application

# SL 120

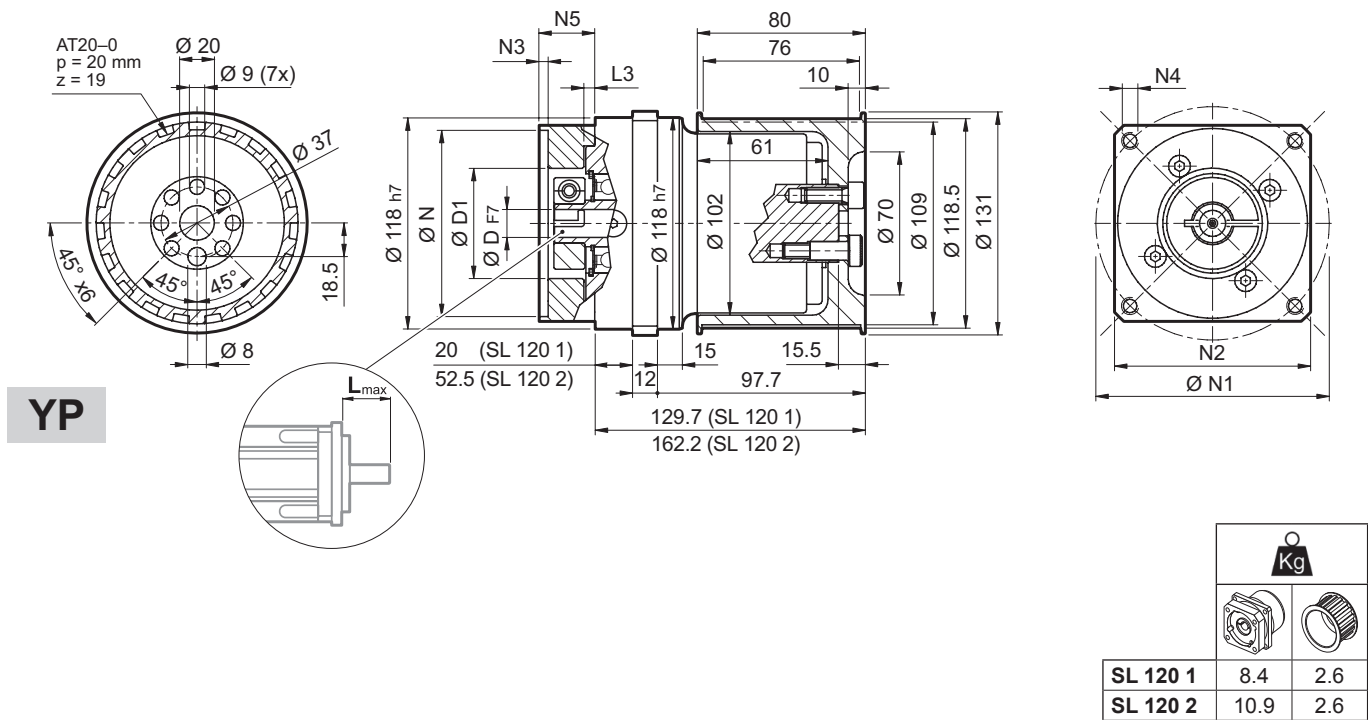

SL

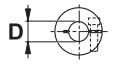
									N	N1	N2	N3	N4	N5	L <sub>max</sub>	
<b>50D</b>	14	15	15.875	16	19	-	-	-	-	50	95	100	5	M6x14	28	40
<b>55A</b>	14	15	15.875	16	19	-	-	-	-	55.5	125.7	105	5	M6x16	28	40
<b>60A2</b>	14	15	15.875	16	19	-	-	-	-	60	75	100	5	M5x14	28	40
<b>60AH2</b>	14	15	15.875	16	19	-	-	-	-	60	75	100	5	6.5	33	40
<b>60B1</b>	14	15	15.875	16	19	-	-	-	-	60	85	100	6.5	M5x14	28	40
<b>70A1</b>	14	15	15.875	16	19	-	-	-	-	70	85	100	5	M6x14	28	40
<b>70AH1</b>	14	15	15.875	16	19	-	-	-	-	70	85	100	5	6	33	40
<b>70B1</b>	14	15	15.875	16	19	-	-	-	-	70	90	100	6.5	M5x12	28	40
<b>80A1</b>	14	15	15.875	16	19	-	-	-	-	80	100	100	5	M6x16	28	40
<b>80AH1</b>	14	15	15.875	16	19	-	-	-	-	80	100	100	5	6.5	28	40
<b>95A</b>	14	15	15.875	16	19	-	-	-	-	95	115	100	5	M8x18	28	40
<b>95A1</b>	14	15	15.875	16	19	22	24	-	-	95	115	100	5	M8x18	38	50
<b>95B</b>	14	15	15.875	16	19	-	-	-	-	95	130	115	5	M8x18	28	40
<b>110A</b>	14	15	15.875	16	19	-	-	-	-	110	130	115	5	M8x18	28	40
<b>110A1</b>	14	15	15.875	16	19	22	24	-	-	110	130	115	6.5	M8x20	38	50
<b>110B</b>	14	15	15.875	16	19	22	24	-	-	110	145	120	6.5	M8x20	38	50
<b>110B1</b>	14	15	15.875	16	19	22	24	28	-	110	145	120	6.5	M8x20	48	60
<b>130A</b>	14	15	15.875	16	19	22	24	-	-	130	165	140	6.5	M10x20	38	50
<b>130A1</b>	14	15	15.875	16	19	22	24	28	32	130	165	140	6.5	M10x25	48	60

Please contact us for different motor adapters and input shaft bore.

# SL 120

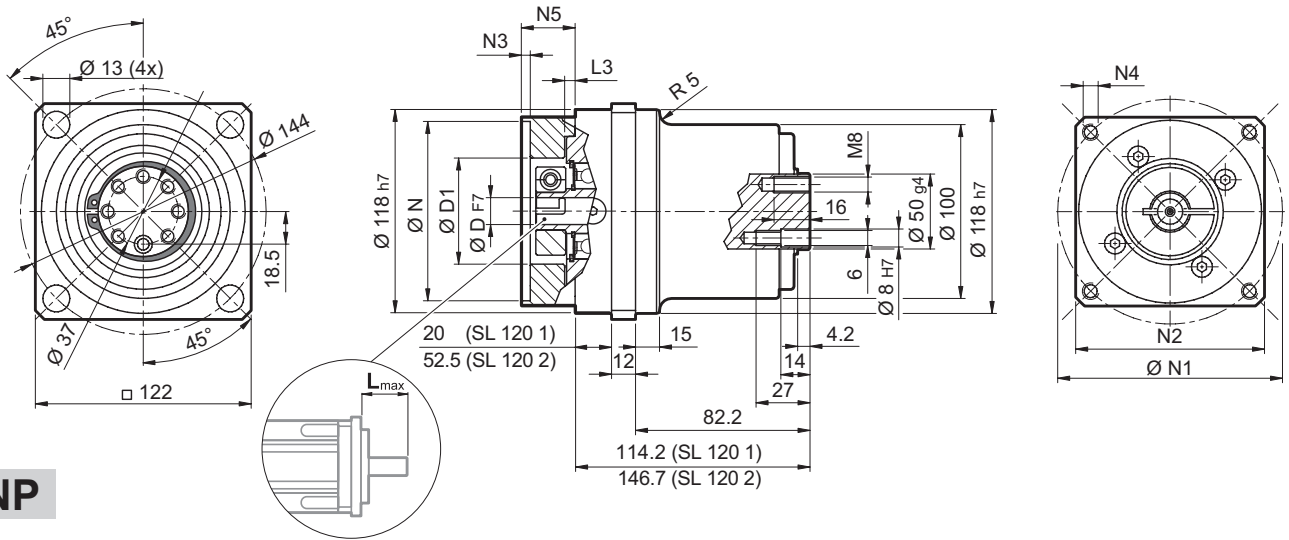

NP

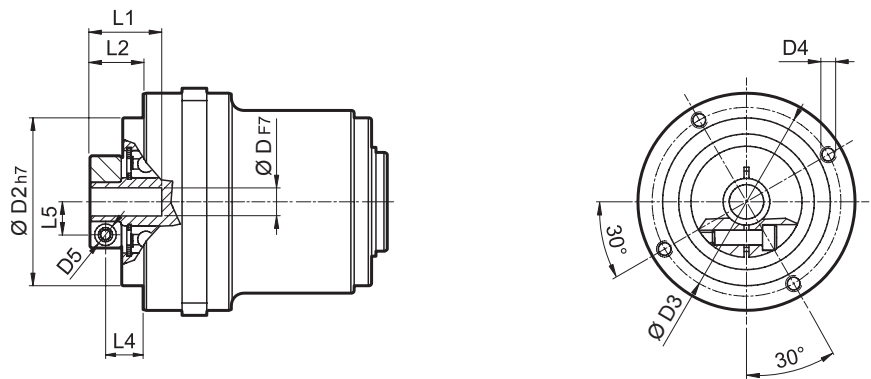

FM

				D1	D2	D3	D4	D5	L1	L2	L3	L4	L5
14	15	15.875	16	48	90	98	M6x15	M6	33.5	20	7.6	12.5	14.5
19				51	90	98	M6x15	M6	33.5	20	7.6	12.5	16.5
22	24			56.5	90	98	M6x15	M6	36.5	23	7.6	14	19
28				70	90	98	M6x15	M8	36.5	23	7.6	14	22.5
32				71	90	98	M6x15	M8	38	24.5	7.6	15.5	24.5

	i	M <sub>n2</sub> [Nm]	M <sub>a2</sub> [Nm]	M <sub>p2</sub> [Nm]	n <sub>1</sub> [min <sup>-1</sup> ]	n <sub>1 max</sub> [min <sup>-1</sup> ]	φ <sub>S</sub> [arcmin]	φ <sub>R</sub> [arcmin]	C <sub>t</sub> [Nm/arcmin]	R <sub>2 max</sub> * [N]	A <sub>2 max</sub> [N]	η %	J <sub>G</sub> [kgcm <sup>2</sup> ]			
													14 ... 19	22 ; 24	28 ; 32	
SL 120 1_3		95	160	300	2500	3500	12'	6'	45	10000	4500	97	2.18	2.81	3.25	50.62
SL 120 1_4		110	190	360	2800	4500	12'	6'	45	10000	4500	97	1.30	1.93	2.37	
SL 120 1_5		110	190	360	3000	4500	12'	6'	45	10000	4500	97	0.96	1.59	2.03	
SL 120 1_7		110	190	360	3500	4500	12'	6'	45	10000	4500	97	0.66	1.28	1.72	
SL 120 1_10		95	160	300	3500	5000	12'	6'	45	10000	4500	97	0.49	1.11	1.55	
SL 120 2_9		95	160	300	2500	3500	15'	8'	40	10000	4500	94	1.61	2.20	2.57	
SL 120 2_12		110	190	360	2500	3500	15'	8'	40	10000	4500	94	1.51	2.10	2.47	
SL 120 2_15		110	190	360	2500	3500	15'	8'	40	10000	4500	94	1.47	2.06	2.43	
SL 120 2_16		110	190	360	2800	4500	15'	8'	40	10000	4500	94	0.92	1.52	1.88	
SL 120 2_20		110	190	360	3000	4500	15'	8'	40	10000	4500	94	0.90	1.50	1.86	
SL 120 2_25		110	190	360	3000	4500	15'	8'	40	10000	4500	94	0.71	1.30	1.67	
SL 120 2_28		110	190	360	3500	5000	15'	8'	40	10000	4500	94	0.54	1.13	1.50	
SL 120 2_30		95	160	300	3500	5000	15'	8'	40	10000	4500	94	0.44	1.04	1.40	
SL 120 2_35		110	190	360	3500	5000	15'	8'	40	10000	4500	94	0.53	1.13	1.49	
SL 120 2_40		110	190	360	3500	5000	15'	8'	40	10000	4500	94	0.43	1.03	1.39	
SL 120 2_50		110	190	360	3500	5000	15'	8'	40	10000	4500	94	0.43	1.02	1.39	
SL 120 2_70		110	190	360	3500	5000	15'	8'	40	10000	4500	94	0.42	1.02	1.38	
SL 120 2_100		95	160	300	3500	5000	15'	8'	40	10000	4500	94	0.42	1.02	1.38	

\* Applies for timing belt application

# SL 070P

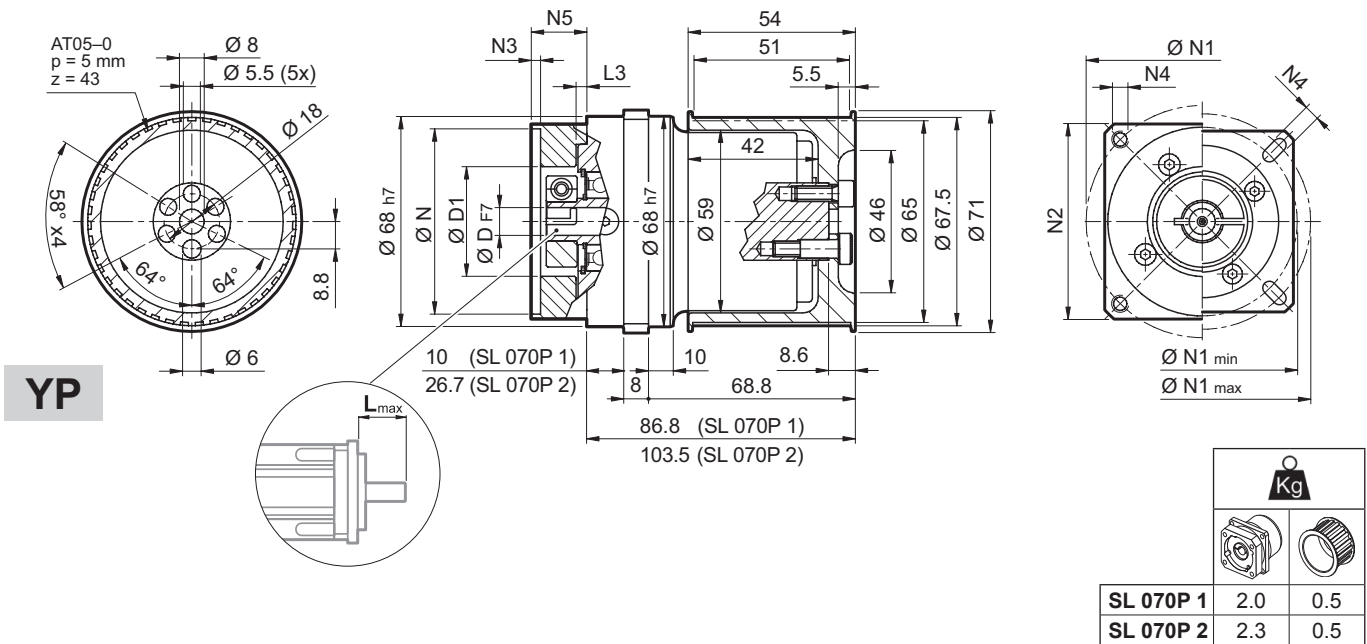

TS

		D												N	N1		N2	N3	N4	N5	L <sub>max</sub>
																min					
25AH	6.35	7	8	9	9.52	-	-	-	-	-	-	25	39	56							
26AH	6.35	7	8	9	9.52	-	-	-	-	-	-	26	39	56							
28AH	6.35	7	8	9	9.52	-	-	-	-	-	-	28	39	56							
30AH	6.35	7	8	9	9.52	-	-	-	-	-	-	30	39	56							
32AH	6.35	7	8	9	9.52	-	-	-	-	-	-	32	39	56	65	3.5	4.5	25	25		
34AH	6.35	7	8	9	9.52	-	-	-	-	-	-	34	40	56							
36AH	6.35	7	8	9	9.52	-	-	-	-	-	-	36	42	56							
39AH	6.35	7	8	9	9.52	-	-	-	-	-	-	39	45	56							
40AH	6.35	7	8	9	9.52	-	-	-	-	-	-	40	46	56							
38B	6.35	7	8	9	9.52	10	11	12	12.7	-	38.1	66.6	60	3	M4x10	18	25				
40B	6.35	7	8	9	9.52	10	11	12	12.7	-	40	63	60	3	M4x10	18	25				
50A	6.35	7	8	9	9.52	10	11	12	12.7	-	50	60	60	3	M4x10	18	25				
50B	6.35	7	8	9	9.52	10	11	12	12.7	14	50	65	60	3	M5x12	23	30				
50BH	6.35	7	8	9	9.52	10	11	12	12.7	14	50	65	65	3	5.5	25	32				
50C	6.35	7	8	9	9.52	10	11	12	12.7	14	50	70	60	3	M4x10	23	30				
55MH	6.35	7	8	9	9.52	10	11	12	12.7	-	55	80	65	2	5.5	16	23				
60A	6.35	7	8	9	9.52	10	11	12	12.7	-	60	75	65	3	M5x12	18	25				
60A1	6.35	7	8	9	9.52	10	11	12	12.7	14	60	75	65	3	M5x12	23	30				
60B	6.35	7	8	9	9.52	10	11	12	12.7	14	60	85	75	3	M5x12	23	30				
60C	6.35	7	8	9	9.52	10	11	12	12.7	14	60	90	75	3	M5x12	23	30				
70A	6.35	7	8	9	9.52	10	11	12	12.7	14	70	85	75	3	M6x15	23	30				
70B	6.35	7	8	9	9.52	10	11	12	12.7	14	70	90	75	5	M5x12	23	30				
73A	6.35	7	8	9	9.52	10	11	12	12.7	14	73	98.4	85	3	M5x12	25	32				
80A	6.35	7	8	9	9.52	10	11	12	12.7	14	80	100	85	3	M6x15	23	30				

Please contact us for different motor adapters and input shaft bore.



# SL 070P

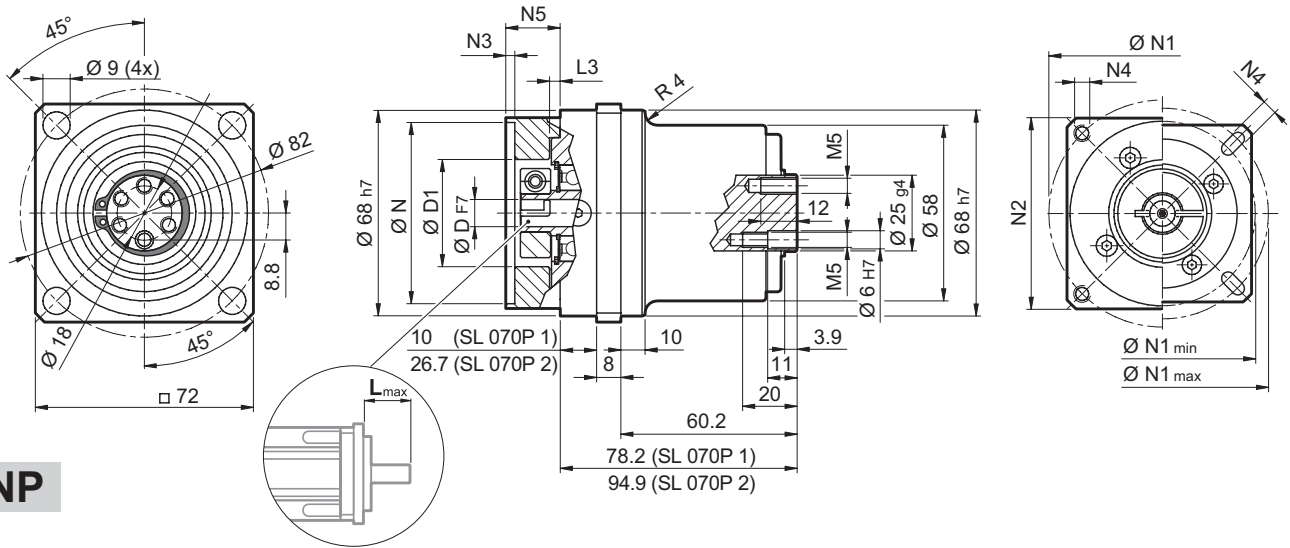

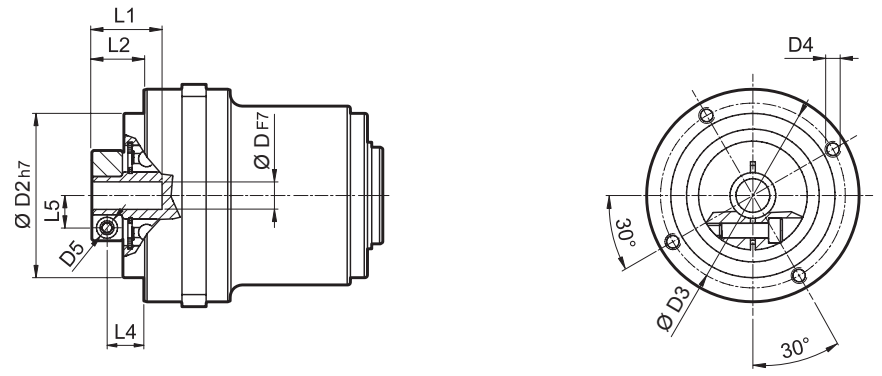

**NP**

**FM**



D				D1	D2	D3	D4	D5	L1	L2	L3	L4	L5
6.35	7			32.5	50	42.5	M4x8	M4	21.7	13.2	3	8.2	8
8	9	9.52	10	32.5	50	42.5	M4x8	M4	21.7	13.2	3	8.2	9
11	12	12.7		35.5	50	42.5	M4x8	M4	22	13.5	3	8.5	11
14				35.5	50	42.5	M4x8	M4	25	17	3	10.2	11.5



 i	M <sub>n2</sub>	M <sub>a2</sub>	M <sub>p2</sub>	n <sub>1</sub>	n <sub>1 max</sub>	ψ <sub>S</sub>	ψ <sub>R</sub>	C <sub>t</sub>	R <sub>2 max</sub> *	A <sub>2 max</sub>	η	J <sub>G</sub> [kgcm <sup>2</sup> ]		 3.86
	[Nm]	[Nm]	[Nm]	[min <sup>-1</sup> ]	[min <sup>-1</sup> ]	[arcmin]	[ $\frac{Nm}{arcmin}$ ]	[N]	[N]	%	6 ... 9.52	11 ... 14		
SL 070P 1_3	29	55	60	3300	4000	12'	6'	6.5	3500	1600	97	0.14	0.16	
SL 070P 1_4	30	45	70	3500	5000	12'	6'	6.5	3500	1600	97	0.09	0.11	
SL 070P 1_5	25	40	70	3500	5000	12'	6'	6.5	3500	1600	97	0.07	0.09	
SL 070P 1_7	25	40	70	4000	5000	12'	6'	6.5	3500	1600	97	0.05	0.07	
SL 070P 1_10	18	30	60	4000	6000	12'	6'	6.5	3500	1600	97	0.04	0.06	
SL 070P 2_9	29	55	60	3300	4000	15'	8'	6	3500	1600	94	0.11	0.13	
SL 070P 2_12	29	55	70	3300	4000	15'	8'	6	3500	1600	94	0.10	0.13	
SL 070P 2_15	29	55	70	3300	4000	15'	8'	6	3500	1600	94	0.10	0.12	
SL 070P 2_16	30	45	70	3500	5000	15'	8'	6	3500	1600	94	0.07	0.09	
SL 070P 2_20	30	45	70	3500	5000	15'	8'	6	3500	1600	94	0.06	0.08	
SL 070P 2_25	30	45	70	3500	5000	15'	8'	6	3500	1600	94	0.06	0.08	
SL 070P 2_28	30	45	70	4000	6000	15'	8'	6	3500	1600	94	0.05	0.07	
SL 070P 2_30	29	55	60	4000	6000	15'	8'	6	3500	1600	94	0.04	0.06	
SL 070P 2_35	30	45	70	4000	6000	15'	8'	6	3500	1600	94	0.05	0.07	
SL 070P 2_40	30	45	70	4000	6000	15'	8'	6	3500	1600	94	0.04	0.06	
SL 070P 2_50	30	45	70	4000	6000	15'	8'	6	3500	1600	94	0.04	0.06	
SL 070P 2_70	30	45	70	4000	6000	15'	8'	6	3500	1600	94	0.04	0.06	
SL 070P 2_100	18	30	60	4000	6000	15'	8'	6	3500	1600	94	0.04	0.06	

\* Applies for timing belt application

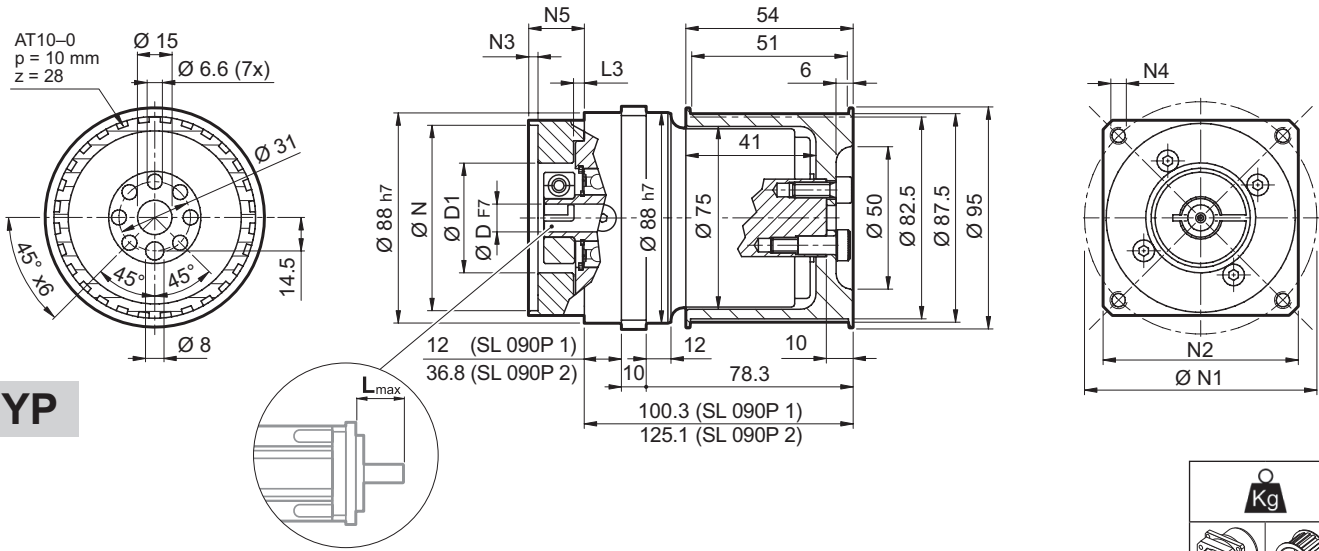

# SL 090P



	Kg	
		
<b>SL 090P 1</b>	3.6	0.8
<b>SL 090P 2</b>	4.7	0.8

TS

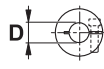
												N	N1	N2	N3	N4	N5	L <sub>max</sub>
40B1	9	9.52	11	12	12.7	14	-	-	-	-	-	40	63	80	4	M4x10	34	40
45A	9	9.52	11	12	12.7	-	-	-	-	-	-	45	63	80	4	M4x10	34	40
50B1	9	9.52	11	12	12.7	14	-	-	-	-	-	50	65	80	4	M5x16	34	40
50BH1	9	9.52	11	12	12.7	14	-	-	-	-	-	50	65	80	4	5.5	34	40
50C1	9	9.52	11	12	12.7	14	-	-	-	-	-	50	70	80	4	M4x10	34	40
50D	9	9.52	11	12	12.7	14	-	-	-	-	-	50	95	80	4	M6x10	34	40
55A	9	9.52	11	12	12.7	14	15.875	16	17	19	19.05	55.5	125.7	105	4	M6x16	34	40
60A2	9	9.52	11	12	12.7	14	-	-	-	-	-	60	75	80	4	M5x16	34	40
60AH2	9	9.52	11	12	12.7	14	-	-	-	-	-	60	75	90	4	5.5	34	40
60B1	9	9.52	11	12	12.7	14	15.875	16	-	-	-	60	85	80	4	M5x16	34	40
60C1	9	9.52	11	12	12.7	14	15.875	16	-	-	-	60	90	80	4	M5x16	34	40
70A1	9	9.52	11	12	12.7	14	15.875	16	17	19	19.05	70	85	80	4	M6x20	34	40
70AH1	9	9.52	11	12	12.7	14	15.875	16	17	19	19.05	70	85	90	4	6.5	34	40
70B1	9	9.52	11	12	12.7	14	15.875	16	17	19	19.05	70	90	80	4	M5x16	34	40
73A1	9	9.52	11	12	12.7	14	-	-	-	-	-	73	98.4	85	4	M5x16	34	40
80A1	9	9.52	11	12	12.7	14	15.875	16	17	19	19.05	80	100	90	4	M6x16	34	40
95A	9	9.52	11	12	12.7	14	15.875	16	17	19	19.05	95	115	100	4	M8x20	34	40
95B	9	9.52	11	12	12.7	14	15.875	16	17	19	19.05	95	130	115	4	M8x20	34	40
110A	9	9.52	11	12	12.7	14	15.875	16	17	19	19.05	110	130	115	4	M8x20	34	40
110B	9	9.52	11	12	12.7	14	15.875	16	17	19	19.05	110	145	120	6.5	M8x20	44	50
110B1	9	9.52	11	12	12.7	14	15.875	16	17	19	19.05	110	145	120	6.5	M8x20	54	60

Please contact us for different motor adapters and input shaft bore.

# SL 090P

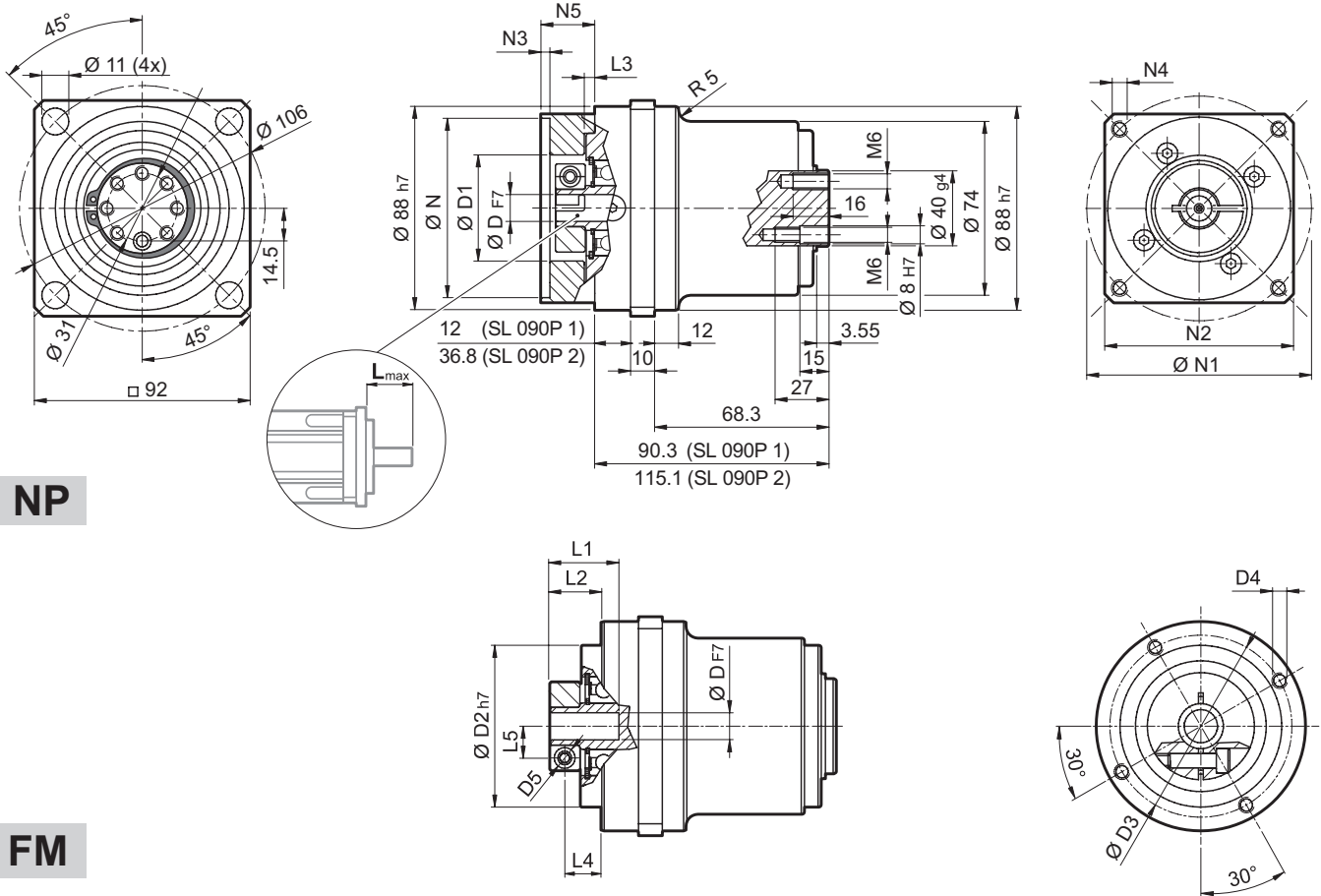

**NP**

**FM**

D		D1	D2	D3	D4	D5	L1	L2	L3	L4	L5
9	9.52	38	68	76.5	M6x10	M6	34	26.8	9.5	18.8	10.5
11	12	52	68	76.5	M6x10	M6	34	26.8	9.5	18.8	12.5
14	15.875	48	68	76.5	M6x10	M6	34	26.8	9.5	18.8	14.5
19	19.05	51	68	76.5	M6x10	M6	34	26.8	9.5	18.8	16.5

i	M <sub>n2</sub> [Nm]	M <sub>a2</sub> [Nm]	M <sub>p2</sub> [Nm]	n <sub>1</sub> [min <sup>-1</sup> ]	n <sub>1 max</sub> [min <sup>-1</sup> ]	φ <sub>S</sub> [arcmin]	φ <sub>R</sub> [arcmin]	C <sub>t</sub> [Nm/arcmin]	R <sub>2 max</sub> * [N]	A <sub>2 max</sub> [N]	η %	J <sub>G</sub> [kgcm <sup>2</sup> ]		10.95
												D		
SL 090P 1_3	65	120	150	3500	4000	12'	6'	12	4500	2000	97	0.72	0.81	10.95
SL 090P 1_4	60	110	160	3500	4000	12'	6'	12	4500	2000	97	0.49	0.58	
SL 090P 1_5	50	100	160	3200	4500	12'	6'	12	4500	2000	97	0.39	0.48	
SL 090P 1_7	50	100	160	4000	6000	12'	6'	12	4500	2000	97	0.31	0.40	
SL 090P 1_10	40	70	150	4000	6000	12'	6'	12	4500	2000	97	0.27	0.35	
SL 090P 2_9	65	120	150	3500	4000	15'	8'	11.5	4500	2000	94	0.47	0.61	
SL 090P 2_12	65	120	160	3500	4000	15'	8'	11.5	4500	2000	94	0.44	0.58	
SL 090P 2_15	65	120	160	3500	4000	15'	8'	11.5	4500	2000	94	0.43	0.57	
SL 090P 2_16	60	110	160	3500	4500	15'	8'	11.5	4500	2000	94	0.31	0.45	
SL 090P 2_20	60	110	160	3500	4500	15'	8'	11.5	4500	2000	94	0.26	0.40	
SL 090P 2_25	50	100	160	3200	4500	15'	8'	11.5	4500	2000	94	0.26	0.40	
SL 090P 2_28	50	100	160	4000	6000	15'	8'	11.5	4500	2000	94	0.22	0.36	
SL 090P 2_30	65	120	150	4000	6000	15'	8'	11.5	4500	2000	94	0.20	0.34	
SL 090P 2_35	50	100	160	4000	6000	15'	8'	11.5	4500	2000	94	0.22	0.36	
SL 090P 2_40	60	110	160	4000	6000	15'	8'	11.5	4500	2000	94	0.20	0.34	
SL 090P 2_50	50	100	160	4000	6000	15'	8'	11.5	4500	2000	94	0.20	0.34	
SL 090P 2_70	50	100	160	4000	6000	15'	8'	11.5	4500	2000	94	0.20	0.34	
SL 090P 2_100	40	70	150	4000	6000	15'	8'	11.5	4500	2000	94	0.19	0.34	

\* Applies for timing belt application

# SL 120P

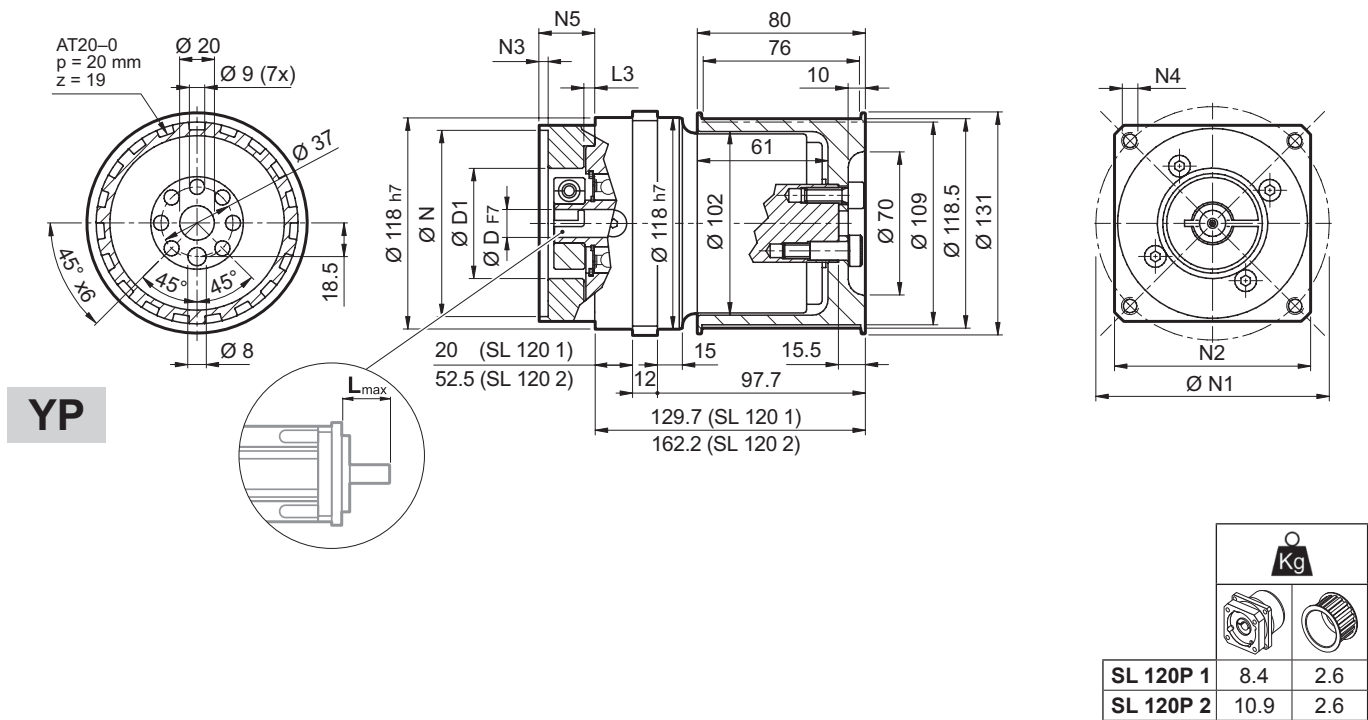

SL

	D								N	N1	N2	N3	N4	N5	L <sub>max</sub>	
<b>50D</b>	14	15	15.875	16	19	-	-	-	-	50	95	100	5	M6x14	28	40
<b>55A</b>	14	15	15.875	16	19	-	-	-	-	55.5	125.7	105	5	M6x16	28	40
<b>60A2</b>	14	15	15.875	16	19	-	-	-	-	60	75	100	5	M5x14	28	40
<b>60AH2</b>	14	15	15.875	16	19	-	-	-	-	60	75	100	5	6.5	33	40
<b>60B1</b>	14	15	15.875	16	19	-	-	-	-	60	85	100	6.5	M5x14	28	40
<b>70A1</b>	14	15	15.875	16	19	-	-	-	-	70	85	100	5	M6x14	28	40
<b>70AH1</b>	14	15	15.875	16	19	-	-	-	-	70	85	100	5	6	33	40
<b>70B1</b>	14	15	15.875	16	19	-	-	-	-	70	90	100	6.5	M5x12	28	40
<b>80A1</b>	14	15	15.875	16	19	-	-	-	-	80	100	100	5	M6x16	28	40
<b>80AH1</b>	14	15	15.875	16	19	-	-	-	-	80	100	100	5	6.5	28	40
<b>95A</b>	14	15	15.875	16	19	-	-	-	-	95	115	100	5	M8x18	28	40
<b>95A1</b>	14	15	15.875	16	19	22	24	-	-	95	115	100	5	M8x18	38	50
<b>95B</b>	14	15	15.875	16	19	-	-	-	-	95	130	115	5	M8x18	28	40
<b>110A</b>	14	15	15.875	16	19	-	-	-	-	110	130	115	5	M8x18	28	40
<b>110A1</b>	14	15	15.875	16	19	22	24	-	-	110	130	115	6.5	M8x20	38	50
<b>110B</b>	14	15	15.875	16	19	22	24	-	-	110	145	120	6.5	M8x20	38	50
<b>110B1</b>	14	15	15.875	16	19	22	24	28	-	110	145	120	6.5	M8x20	48	60
<b>130A</b>	14	15	15.875	16	19	22	24	-	-	130	165	140	6.5	M10x20	38	50
<b>130A1</b>	14	15	15.875	16	19	22	24	28	32	130	165	140	6.5	M10x25	48	60

Please contact us for different motor adapters and input shaft bore.

# SL 120P

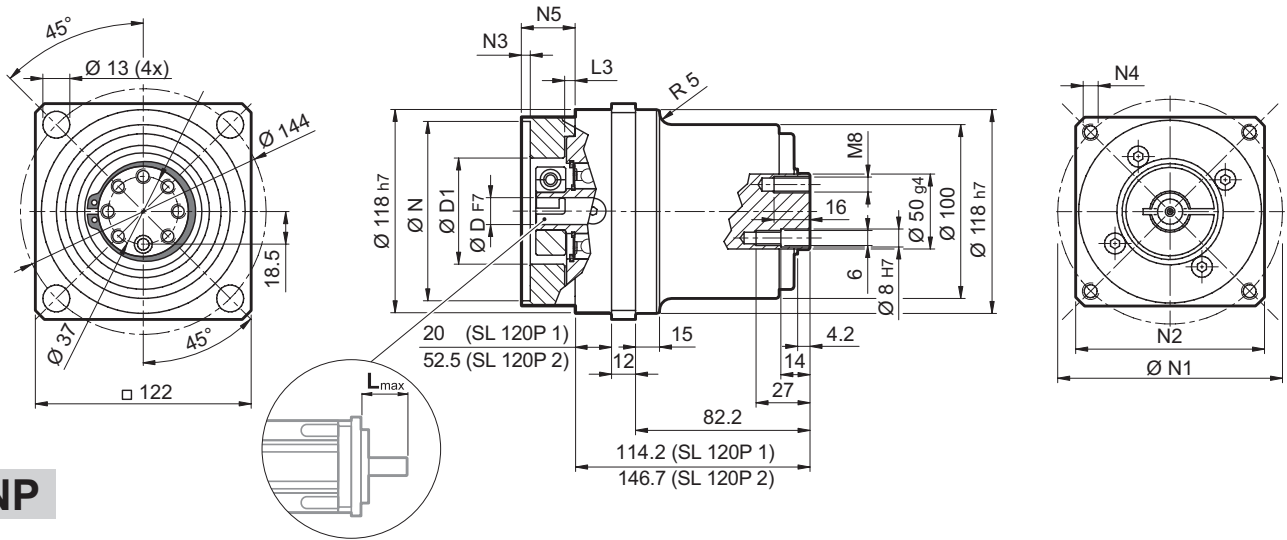

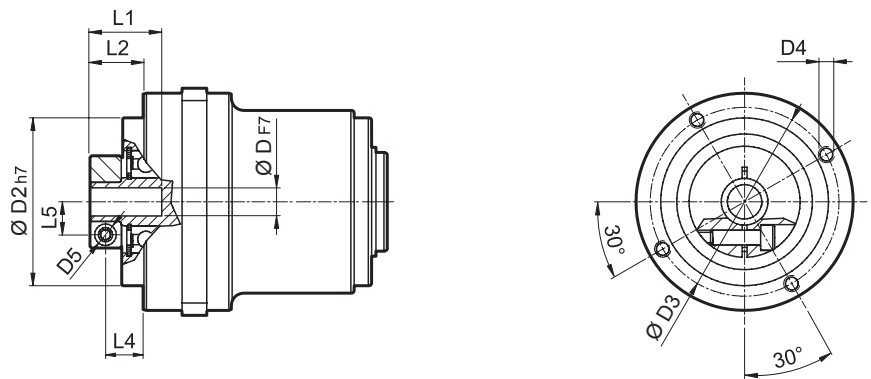

NP



FM

				D1	D2	D3	D4	D5	L1	L2	L3	L4	L5
14	15	15.875	16	48	90	98	M6x15	M6	33.5	20	7.6	12.5	14.5
19				51	90	98	M6x15	M6	33.5	20	7.6	12.5	16.5
22	24			56.5	90	98	M6x15	M6	36.5	23	7.6	14	19
28				70	90	98	M6x15	M8	36.5	23	7.6	14	22.5
32				71	90	98	M6x15	M8	38	24.5	7.6	15.5	24.5

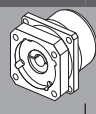
TS

	$M_{n2}$	$M_{a2}$	$M_{p2}$	$n_1$	$n_{1max}$	$\varphi_s$	$\varphi_R$	$C_t$	$R_{2max}^*$	$A_{2max}$	$\eta$	$J_G$ [kgcm <sup>2</sup> ]			
												$D$ 	14 ... 19	22 ; 24	
SL 120P 1_3	155	280	300	3000	4000	12'	6'	45	10000	4500	97	2.18	2.81	3.25	50.62
SL 120P 1_4	155	300	360	3000	4500	12'	6'	45	10000	4500	97	1.30	1.93	2.37	
SL 120P 1_5	125	240	360	3000	4500	12'	6'	45	10000	4500	97	0.96	1.59	2.03	
SL 120P 1_7	125	240	360	3500	4500	12'	6'	45	10000	4500	97	0.66	1.28	1.72	
SL 120P 1_10	100	160	300	3500	5000	12'	6'	45	10000	4500	97	0.49	1.11	1.55	
SL 120P 2_9	155	280	300	3000	4000	15'	8'	40	10000	4500	94	1.61	2.20	2.57	
SL 120P 2_12	155	300	360	3000	4000	15'	8'	40	10000	4500	94	1.51	2.10	2.47	
SL 120P 2_15	155	300	360	3000	4000	15'	8'	40	10000	4500	94	1.47	2.06	2.43	
SL 120P 2_16	155	300	360	3000	4500	15'	8'	40	10000	4500	94	0.92	1.52	1.88	
SL 120P 2_20	155	300	360	3000	4500	15'	8'	40	10000	4500	94	0.90	1.50	1.86	
SL 120P 2_25	125	240	360	3000	4500	15'	8'	40	10000	4500	94	0.71	1.30	1.67	
SL 120P 2_28	125	240	360	3500	5000	15'	8'	40	10000	4500	94	0.54	1.13	1.50	
SL 120P 2_30	155	300	300	3500	5000	15'	8'	40	10000	4500	94	0.44	1.04	1.40	
SL 120P 2_35	125	240	360	3500	5000	15'	8'	40	10000	4500	94	0.53	1.13	1.49	
SL 120P 2_40	155	300	360	3500	5000	15'	8'	40	10000	4500	94	0.43	1.03	1.39	
SL 120P 2_50	125	240	360	3500	5000	15'	8'	40	10000	4500	94	0.43	1.02	1.39	
SL 120P 2_70	125	240	360	3500	5000	15'	8'	40	10000	4500	94	0.42	1.02	1.38	
SL 120P 2_100	100	160	300	3500	5000	15'	8'	40	10000	4500	94	0.42	1.02	1.38	

\* Applies for timing belt application