

2.0	RIDUTTORI A VITE SENZA FINE X	X WORM GEARBOXES	SCHNECKENGETRIEBE X	
2.1	Caratteristiche	<i>Characteristics</i>	Merkmale	16
2.2	Designazione	<i>Designation</i>	Bezeichnung	17
2.3	Lubrificazione e posizioni di montaggio	<i>Lubrication and mounting position</i>	Schmierung und Einbaulage	18
2.4	Posizione morsettiera	<i>Terminal board position</i>	Lage des Klemmbrett	18
2.5	Dati tecnici	<i>Technical data</i>	Technische Daten	19
2.6	Momenti d'inerzia	<i>Moment of inertia</i>	Trägheitsmoment	27
2.7	Dimensioni	<i>Dimensions</i>	Abmessungen	30
2.8	Entrata supplementare	<i>Additional input</i>	Zusatzantrieb	35
2.9	Limitatore di coppia cavo passante	<i>Torque limiter with through hollow shaft</i>	Drehmomentbegrenzer mit durchgehender Hohlwelle	35
2.10	Accessori	<i>Accessories</i>	Zubehör	37
2.11	Lista parti di ricambio	<i>Spare parts list</i>	Ersatzteilliste	38

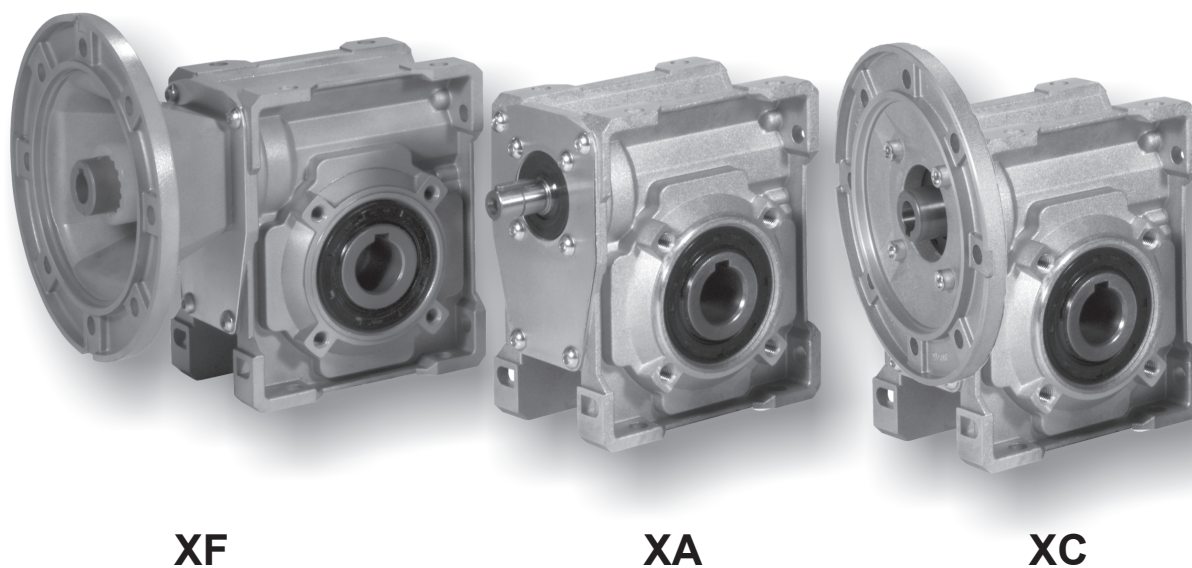



2.1 Caratteristiche

- I riduttori a vite senza fine della serie X sono disponibili nelle versioni alberata XA e con predisposizione per attacco motore XF-XC.
- La versione XF (campana + giunto), caratterizzata da una più ampia versatilità ai diversi tipi di applicazioni, presenta un più elevato rendimento rispetto a quello della serie compatta XC la quale, a sua volta, presenta il vantaggio di un ingombro più ridotto.
- La carcassa monoblocco è in ghisa nelle grandezze 90, 110 e 130, in alluminio pressofuso per le grandezze inferiori.
- La vite senza fine è in acciaio legato cementato-temprato ed è rettificata.
- La corona ha il mozzo in ghisa con riporto di fusione dell'anello in bronzo.
- Le carcasse in ghisa sono verniciate BLU RAL5010 mentre quelle in alluminio sono sabbiate.
- Viene fornito l'albero uscita cavo di serie ed esiste un'ampia disponibilità di accessori: seconda entrata, cuscinetti conici sulla corona, flangia uscita, albero lento con 1 o 2 sporgenze, limitatore di coppia con cavo passante, braccio di reazione, kit protezione albero cavo, kit protezione limitatore di coppia.

2.1 Characteristics

- *X series worm gearboxes are available in the following versions : XA with shaft, XF and XC suitable for motor mounting assembling.*
- *The XF version (bell + joint) suits a wider range of applications and provides higher efficiency than the XC compact version, which actually offers reduced space requirement.*
- *The enbloc housing is in cast-iron for sizes 90, 110 and 130, in die-cast aluminium for smaller sizes.*
- *The worm shaft is in case-and quench-hardened alloy steel and ground.*
- *The worm wheel has a cast-iron hub provided with inserted cast-bronze ring.*
- *The housings in cast iron are painted BLUE RAL 5010, those in aluminium are sandblasted.*
- *The hollow output shaft is supplied as standard. A broad range of accessories is available: second input, tapered roller bearings on the worm wheel, output flange, single or double-extended output shaft, torque limiter with through hollow shaft, torque arm, hollow shaft protection kit, torque limiter protection kit.*

2.1 Merkmale

- Die Schneckengetriebe der Serie X sind in die Version XA mit Welle und XF / XC mit Motoranschluß lieferbar.
- Die Version XF (Glocke + Kupplung), die sich durch ihre zahlreichen Anwendungsmöglichkeiten auszeichnet, bietet höhere Leistung als die Kompaktserie XC, die wiederum Vorteile im Sinne der Platzersparnis mit sich bringt.
- Das Blockgehäuse ist aus Gusseisen für die Baugrößen 90, 110 und 130, aus Aluminiumdruckguß für die kleineren Versionen.
- Die Schnecke ist aus einsatzgehärtetem/abgeschrecktem und daraufhin geschliffenen Legierungsstahl.
- Das Schneckenrad besteht aus einer Nabe aus Gusseisen und einem aufgeschleuderten Gussbronze –Ring.
- Das Schneckenrad aus Gusseisen werden mit BLAU RAL 5010 lackiert, die aus Aluminium werden sandgestrahlt.
- Die Hohlwelle gehört zur serienmäßigen Ausstattung. Zahlreiches Zubehör ist lieferbar: zweiter Antrieb, Kegellager auf das Schneckenrad, Abtriebsflansch, Standard oder doppelseitig herausragende Abtriebswelle, Drehmomentbegrenzer mit durchgehender Hohlwelle, Drehmomentstütze, Schutzvorrichtung für Hohlwelle, Schutzvorrichtung für Drehmomentbegrenzer.

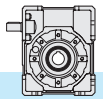

2.2 Designazione

2.2 Designation

2.2 Bezeichnung

Riduttore Gearbox Getriebe	Tipo entrata Input type Antriebsart	Grandezza Size Größe	Rapporto rid. Ratio Untersetzung	Predispos. att. mot. Motor coupling Motoranschluss	Posizione di mont. Mounting position Einbaulage	Flangia in uscita. Output flange Abtriebsflansch	Limitatore di coppia. Torque limiter Drehmomentbegrenzer	Seconda entrata Additional input Zusatzantrieb	Albero uscita Output shaft Abtriebswelle	Braccio di reazione Torque arm Drehmomentstütze
X	A	50	10/1	P.A.M	B3	F1S	LD	SeA	H	BR
Riduttore a vite senza fine Wormgearbox Schneckengetriebe	A	30	5	56		F1D-F2D-F3D	LD	SeA	H	BR
	C	40 50 63 75 90 110 130	7.5 10 15 20 25 30 40 50 65 80 100	63 71 80 90 100 112 132	B3, B6 B7, B8 V5, V6	F1S-F2S-F3S	LS		SD	
	F					F12-F22-F32			SS DD	

Tipo entrata

Input type

Antriebstyp

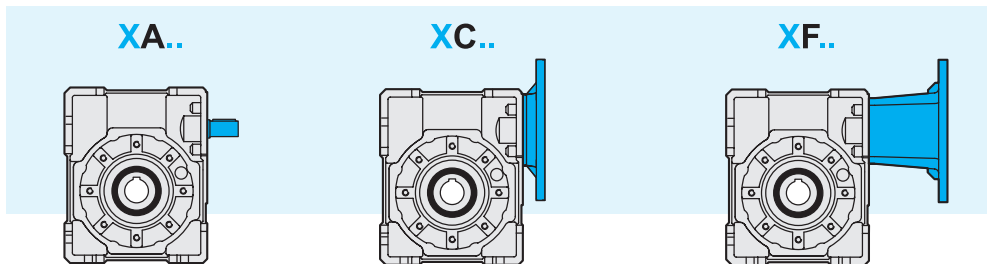



2.3 Lubrificazione

I riduttori a vite senza fine serie X, tranne la grandezza 130, sono forniti completi di lubrificante sintetico a base PAG con indice di viscosità ISO VG320. Si raccomanda di precisare sempre, in fase di ordine, la posizione di lavoro desiderata.

Posizioni di montaggio

2.3 Lubrication

X series worm gearboxes, except for the size 130, are supplied with synthetic lubricant, PAG base, viscosity index ISO VG320. Mounting position always to be specified when ordering.

Mounting positions

2.3 Schmierung

Schneckengetriebe der Serie X, außer Größe 130, werden mit synthetischem Schmiermittel auf PAG Basis und Viskosität Index ISO VG320 geliefert. Im Auftrag bitte immer die gewünschte Einbaulage angeben.

Einbaulagen

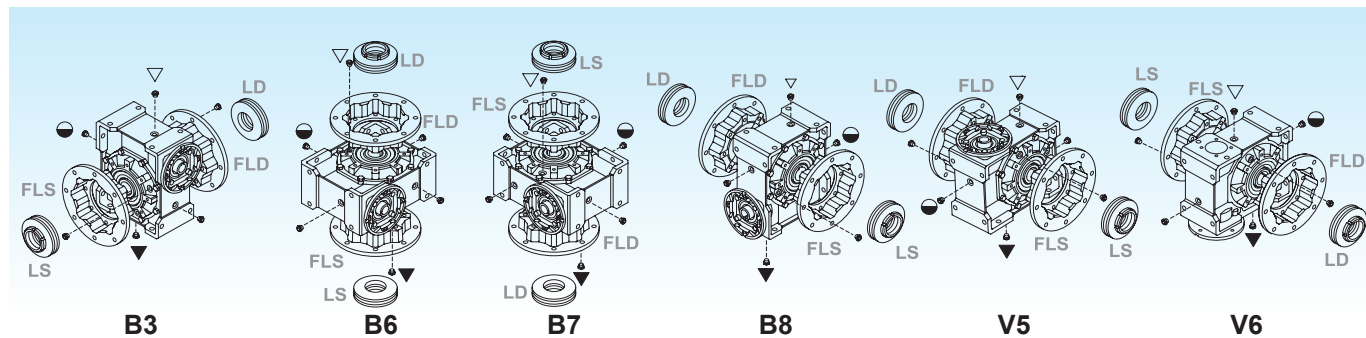

		Q.tà olio / Oil quantity / Schmiermittelmenge [lt]			
		Posizione di montaggio / Mounting position / Einbaulage			
		B3	B6 - B7	B8	V5 - V6
X	30	0.015	0.030		0.015
	40	0.040	0.060		0.040
	50	0.080	0.120		0.080
	63	0.160	0.220		0.160
	75	0.260	0.340		0.260
	90	1.1	0.9	1	1.5
	110	2.2	1.8	1.6	2.6
130	3.6	3	2.5	3.8	

- ▽ Carico e sfiato / Filling and breather
Einfüll und Entlüftung
- Livello / Level / Ölstand
- ▼ Scarico / Drain / Ablass

Nei corpi in alluminio 30, 40, 50, 63,75 è presente un solo tappo di riempimento olio.

30, 40, 50, 63 and 75 aluminium housings have one oil filling plug only.

30, 40, 50, 63 und 75 Aluminiumgehäuse verfügen über 1 Einfüllschraube.

2.4 Posizione morsettiera

2.4 Terminal board position

2.4 Lage der Klemmenkaste

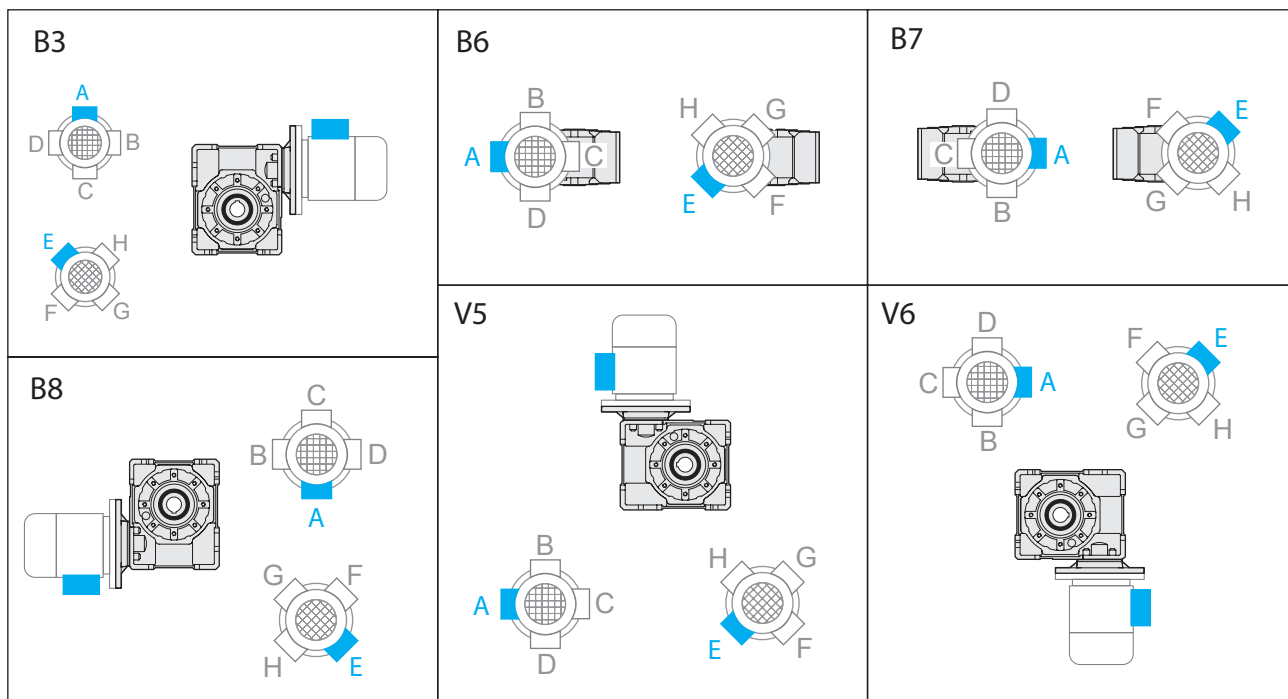

Specificare sempre in fase di ordinazione la posizione di montaggio e la forma costruttiva. Posizione morsettiera v. pag. 33-34 (PM=1; PM=2)

Mounting position always to be specified when ordering. Terminal board position see page 33-34 (PM=1; PM=2)

Bei der Bestellung immer die gewünschte Montageposition und Bauform angeben. Lage der Klemmenkaste Seite 33-34 (PM=1; PM=2)



2.5 Dati tecnici

2.5 Technical data

2.5 Technische Daten

30	$n_1 = 2800$				XA		XC - XF								
	i_n	n_2 [min ⁻¹]	Rd	P_{10}	T_{2M} [Nm]	P [kW]	T_2 [Nm]	P_1 [kW]	FS'	Input - IEC					
										XC	XF				
	B5/B14			B5	B14										
Kg 1.4	5	560	0.89	—	14	0.92	5.6	0.37	2.5	63	56	63	56	63	56
	7.5	373	0.86		16	0.72	8	0.37	2.0						
	10	280	0.84		16	0.56	11	0.37	1.5						
	15	187	0.81		17	0.41	15	0.37	1.1						
	20	140	0.76		15	0.29	13	0.25	1.2						
	25	112	0.74		16	0.25	16	0.25	1.0						
	30	93	0.71		13	0.18	13	0.18	1.0						
	40	70	0.65		16	0.18	16	0.18	1.0						
	50	56	0.62		15	0.14	14	0.13	1.1						
	65	43	0.57		17	0.13	17	0.13	1.0						
80	35	0.54	13	0.09	13	0.09	1.0								
100	28	0.52	12	0.07	16	0.09	0.8	—	—	—	—	—	—		

30	$n_1 = 1400$				XA		XC - XF								
	i_n	n_2 [min ⁻¹]	Rd	P_{10}	T_{2M} [Nm]	P [kW]	T_2 [Nm]	P_1 [kW]	FS'	Input - IEC					
										XC	XF				
	B5/B14			B5	B14										
Kg 1.4	5	280	0.87	0.40	19	0.64	6.5	0.22	2.9	63	56	63	56	63	56
	7.5	187	0.84	0.40	21	0.49	9	0.22	2.2						
	10	140	0.82	0.40	22	0.40	12	0.22	1.8						
	15	93	0.77	0.30	22	0.28	17	0.22	1.3						
	20	70	0.72	0.20	19	0.19	18	0.18	1.1						
	25	56	0.69	0.20	21	0.18	21	0.18	1.0						
	30	47	0.66	0.20	20	0.15	18	0.13	1.1						
	40	35	0.59	0.20	21	0.13	21	0.13	1.0						
	50	28	0.55	0.20	19	0.10	17	0.09	1.1						
	65	22	0.51	0.10	20	0.09	20	0.09	1.0						
80	18	0.48	0.10	17	0.06	16	0.06	1.0							
100	14	0.45	0.10	14	0.05	18	0.06	0.8	—	—	—	—	—	—	

30	$n_1 = 900$				XA		XC - XF								
	i_n	n_2 [min ⁻¹]	Rd	P_{10}	T_{2M} [Nm]	P [kW]	T_2 [Nm]	P_1 [kW]	FS'	Input - IEC					
										XC	XF				
	B5/B14			B5	B14										
Kg 1.4	5	180	0.85	—	23	0.51	5.9	0.13	3.9	63	56	63	56	63	56
	7.5	120	0.82		25	0.38	9	0.13	2.9						
	10	90	0.80		25	0.30	11	0.13	2.3						
	15	60	0.75		25	0.21	15	0.13	1.6						
	20	45	0.69		22	0.15	19	0.13	1.2						
	25	36	0.66		24	0.14	23	0.13	1.1						
	30	30	0.63		21	0.10	18	0.09	1.2						
	40	23	0.55		24	0.10	21	0.09	1.1						
	50	18	0.52		21	0.08	16	0.06	1.1						
	65	14	0.48		22	0.07	20	0.06	1.1						
80	11	0.44	19	0.05	11	0.03	1.7								
100	9	0.42	15	0.03	13	0.03	1.1	—	—	—	—	—	—		

30	$n_1 = 500$				XA		XC - XF								
	i_n	n_2 [min ⁻¹]	Rd	P_{10}	T_{2M} [Nm]	P [kW]	T_2 [Nm]	P_1 [kW]	FS'	Input - IEC					
										XC	XF				
	B5/B14			B5	B14										
Kg 1.4	5	100	0.83	—	29	0.36	—	—	—	63	56	63	56	63	56
	7.5	67	0.80		31	0.27	—	—	—						
	10	50	0.77		31	0.21	—	—	—						
	15	33	0.72		31	0.15	—	—	—						
	20	25	0.66		26	0.10	—	—	—						
	25	20	0.62		27	0.09	—	—	—						
	30	17	0.59		25	0.07	—	—	—						
	40	13	0.51		28	0.07	—	—	—						
	50	10	0.48		25	0.06	—	—	—						
	65	8	0.43		25	0.05	—	—	—						
80	6	0.40	20	0.03	—	—	—								
100	5	0.38	16	0.02	—	—	—	—	—	—	—	—	—		

* **ATTENZIONE:** la coppia massima utilizzabile $[T_{2M}]$ deve essere calcolata utilizzando il fattore di servizio: $T_{2M} = T_2 \times FS'$

* **WARNING:** Maximum allowable torque $[T_{2M}]$ must be calculated using the following service factor: $T_{2M} = T_2 \times FS'$

* **ACHTUNG:** das max. anwendbare Drehmoment $[T_{2M}]$ muss mit folgendem Betriebsfaktor berechnet werden: $T_{2M} = T_2 \times FS'$

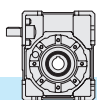

2.5 Dati tecnici

2.5 Technical data

2.5 Technische Daten

40	$n_1 = 2800$				XA		XC - XF											
	i_n	n_2 [min ⁻¹]	Rd	P_{10}	T_{2M} [Nm]	P [kW]	T_2 [Nm]	P_1 [kW]	FS'	XC		Input - IEC						
										B5/B14		B5			XF			B14
Kg 2.4	5	560	0.88	—	25	1.67	11.3	0.75	2.2	71	63	—	71	63	56	71	63	—
	7.5	373	0.87		30	1.3	17	0.75	1.8									
	10	280	0.86		31	1.1	22	0.75	1.4									
	15	187	0.82		32	0.76	32	0.75	1.0									
	20	140	0.80		31	0.57	30	0.55	1.0									
	25	112	0.76		27	0.41	24	0.37	1.1									
	30	93	0.73		35	0.47	28	0.37	1.3									
	40	70	0.70		33	0.35	24	0.25	1.4									
	50	56	0.65		30	0.27	28	0.25	1.1									
	65	43	0.61		28	0.21	24	0.18	1.2									
80	35	0.58	26	0.16	21	0.13	1.3											
100	28	0.55	25	0.13	24	0.13	1.0											

40	$n_1 = 1400$				XA		XC - XF											
	i_n	n_2 [min ⁻¹]	Rd	P_{10}	T_{2M} [Nm]	P [kW]	T_2 [Nm]	P_1 [kW]	FS'	XC		Input - IEC						
										B5/B14		B5			XF			B14
Kg 2.4	5	280	0.87	0.80	34	1.14	16.3	0.55	2.1	71	63	—	71	63	56	71	63	—
	7.5	187	0.85	0.80	40	0.92	24	0.55	1.7									
	10	140	0.83	0.70	41	0.73	31	0.55	1.3									
	15	93	0.79	0.50	42	0.52	30	0.37	1.4									
	20	70	0.76	0.50	40	0.39	38	0.37	1.0									
	25	56	0.72	0.40	35	0.29	31	0.25	1.1									
	30	47	0.68	0.40	41	0.29	35	0.25	1.2									
	40	35	0.64	0.30	38	0.22	38	0.22	1.0									
	50	28	0.59	0.30	38	0.19	36	0.18	1.1									
	65	22	0.54	0.20	35	0.15	31	0.13	1.1									
80	18	0.52	0.20	33	0.12	31	0.11	1.1										
100	14	0.49	0.20	28	0.08	30	0.09	0.9										

40	$n_1 = 900$				XA		XC - XF											
	i_n	n_2 [min ⁻¹]	Rd	P_{10}	T_{2M} [Nm]	P [kW]	T_2 [Nm]	P_1 [kW]	FS'	XC		Input - IEC						
										B5/B14		B5			XF			B14
Kg 2.4	5	180	0.85	—	42	0.93	16.7	0.37	2.5	71	63	—	71	63	56	71	63	—
	7.5	120	0.83		48	0.72	25	0.37	2.0									
	10	90	0.81		48	0.56	32	0.37	1.5									
	15	60	0.76		49	0.40	45	0.37	1.1									
	20	45	0.74		46	0.29	39	0.25	1.2									
	25	36	0.69		42	0.23	33	0.18	1.3									
	30	30	0.65		48	0.23	37	0.18	1.3									
	40	23	0.61		42	0.16	33	0.13	1.3									
	50	18	0.55		42	0.14	38	0.13	1.1									
	65	14	0.51		39	0.11	32	0.09	1.2									
80	11	0.48	37	0.09	37	0.09	1.0											
100	9	0.45	30	0.06	29	0.06	1.0											

40	$n_1 = 500$				XA		XC - XF											
	i_n	n_2 [min ⁻¹]	Rd	P_{10}	T_{2M} [Nm]	P [kW]	T_2 [Nm]	P_1 [kW]	FS'	XC		Input - IEC						
										B5/B14		B5			XF			B14
Kg 2.4	5	100	0.83	—	51	0.64	7.1	0.09	7.1	71	63	—	71	63	56	71	63	—
	7.5	67	0.81		58	0.50	10	0.09	5.5									
	10	50	0.79		59	0.39	14	0.09	4.4									
	15	33	0.73		59	0.28	19	0.09	3.1									
	20	25	0.70		55	0.20	24	0.09	2.3									
	25	20	0.65		48	0.15	28	0.09	1.7									
	30	17	0.61		58	0.17	31	0.09	1.8									
	40	13	0.57		52	0.12	39	0.09	1.3									
	50	10	0.51		51	0.11	44	0.09	1.2									
	65	8	0.46		45	0.08	52	0.09	0.9									
80	6	0.44	42	0.06	61*	0.09	0.7*											
100	5	0.41	32	0.04	71*	0.09	0.4*											

* **ATTENZIONE:** la coppia massima utilizzabile $[T_{2M}]$ deve essere calcolata utilizzando il fattore di servizio: $T_{2M} = T_2 \times FS'$

* **WARNING:** Maximum allowable torque $[T_{2M}]$ must be calculated using the following service factor: $T_{2M} = T_2 \times FS'$

* **ACHTUNG:** das max. anwendbare Drehmoment $[T_{2M}]$ muss mit folgendem Betriebsfaktor berechnet werden: $T_{2M} = T_2 \times FS'$

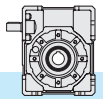

2.5 Dati tecnici

2.5 Technical data

2.5 Technische Daten

50	$n_1 = 2800$				XA		XC - XF											
	i_n	n_2 [min ⁻¹]	Rd	P_{10}	T_{2M} [Nm]	P [kW]	T_2 [Nm]	P_1 [kW]	FS'	Input - IEC								
										XC			XF					
	B5/B14			B5			B14											
4.0	5	560	0.89	—	44	2.9	22.8	1.5	1.9	80	71	—	80	71	63	80	71	—
	7.5	373	0.88		51	2.3	34	1.5	1.5									
	10	280	0.86		54	1.8	44	1.5	1.2									
	15	187	0.84		57	1.3	47	1.1	1.2									
	20	140	0.81		58	1.0	42	0.75	1.4									
	25	112	0.78		50	0.75	50	0.75	1.0									
	30	93	0.75		55	0.71	42	0.55	1.3									
	40	70	0.72		54	0.63	54	0.55	1.0									
	50	56	0.68		56	0.48	43	0.37	1.3									
	65	43	0.64		53	0.37	53	0.37	1.0									
	80	35	0.61		48	0.29	41	0.25	1.2									
	100	28	0.58		45	0.23	35	0.18	1.3									

50	$n_1 = 1400$				XA		XC - XF											
	i_n	n_2 [min ⁻¹]	Rd	P_{10}	T_{2M} [Nm]	P [kW]	T_2 [Nm]	P_1 [kW]	FS'	Input - IEC								
										XC			XF					
	B5/B14			B5			B14											
4.0	5	280	0.87	1.2	62	2.1	26.7	0.9	2.3	80	71	—	80	71	63	80	71	—
	7.5	187	0.86	1.2	70	1.6	40	0.9	1.8									
	10	140	0.84	1.0	73	1.3	52	0.9	1.4									
	15	93	0.80	0.80	74	0.90	74	0.9	1.0									
	20	70	0.78	0.70	75	0.71	58	0.55	1.3									
	25	56	0.74	0.60	65	0.51	47	0.37	1.4									
	30	47	0.71	0.60	66	0.46	53	0.37	1.2									
	40	35	0.67	0.50	69	0.38	68	0.37	1.0									
	50	28	0.62	0.40	70	0.33	53	0.25	1.3									
	65	22	0.58	0.40	64	0.25	64	0.25	1.0									
	80	18	0.54	0.40	60	0.20	53	0.18	1.1									
	100	14	0.51	0.30	55	0.16	45	0.13	1.2									

50	$n_1 = 900$				XA		XC - XF											
	i_n	n_2 [min ⁻¹]	Rd	P_{10}	T_{2M} [Nm]	P [kW]	T_2 [Nm]	P_1 [kW]	FS'	Input - IEC								
										XC			XF					
	B5/B14			B5			B14											
4.0	5	180	0.85	—	75	1.66	33.8	0.75	2.2	80	71	—	80	71	63	80	71	—
	7.5	120	0.84		83	1.23	50	0.75	1.6									
	10	90	0.82		86	0.98	66	0.75	1.3									
	15	60	0.78		88	0.71	68	0.55	1.3									
	20	45	0.75		87	0.54	59	0.37	1.5									
	25	36	0.71		75	0.40	70	0.37	1.1									
	30	30	0.67		79	0.37	79	0.37	1.0									
	40	23	0.63		75	0.28	67	0.25	1.1									
	50	18	0.59		80	0.26	78	0.25	1.0									
	65	14	0.54		74	0.20	67	0.18	1.1									
	80	11	0.51		67	0.16	56	0.13	1.2									
	100	9	0.47		58	0.12	45	0.09	1.3									

50	$n_1 = 500$				XA		XC - XF											
	i_n	n_2 [min ⁻¹]	Rd	P_{10}	T_{2M} [Nm]	P [kW]	T_2 [Nm]	P_1 [kW]	FS'	Input - IEC								
										XC			XF					
	B5/B14			B5			B14											
4.0	5	100	0.84	—	92	1.15	14.3	0.18	6.4	80	71	—	80	71	63	80	71	—
	7.5	67	0.82		100	0.85	21	0.18	4.7									
	10	50	0.80		104	0.68	28	0.18	3.8									
	15	33	0.75		106	0.49	39	0.18	2.7									
	20	25	0.72		104	0.38	50	0.18	2.1									
	25	20	0.68		88	0.27	58	0.18	1.5									
	30	17	0.63		98	0.27	65	0.18	1.5									
	40	13	0.59		95	0.21	81	0.18	1.2									
	50	10	0.54		94	0.18	93	0.18	1.0									
	65	8	0.50		86	0.14	56	0.09	1.5									
	80	6	0.46		77	0.11	63	0.09	1.2									
	100	5	0.43		61	0.07	74	0.09	0.8									

* **ATTENZIONE:** la coppia massima utilizzabile $[T_{2M}]$ deve essere calcolata utilizzando il fattore di servizio: $T_{2M} = T_2 \times FS'$

* **WARNING:** Maximum allowable torque $[T_{2M}]$ must be calculated using the following service factor: $T_{2M} = T_2 \times FS'$

* **ACHTUNG:** das max. anwendbare Drehmoment $[T_{2M}]$ muss mit folgendem Betriebsfaktor berechnet werden: $T_{2M} = T_2 \times FS'$

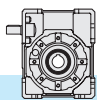

2.5 Dati tecnici

2.5 Technical data

2.5 Technische Daten

63	$n_1 = 2800$				XA		XC - XF											
	i_n	n_2 [min ⁻¹]	Rd	P_{t0}	T_{2M} [Nm]	P [kW]	T_2 [Nm]	P_1 [kW]	FS'	Input - IEC								
										XC			XF					
	B5/B14			B5			B14											
5	560	0.89	—	79	5.2	45.5	3	1.7	90	80	—	90	80	71	90	80	—	
7.5	373	0.88		88	3.9	68	3	1.3										
10	280	0.87		94	3.2	89	3	1.1										
15	187	0.84		98	2.3	95	2.2	1.0										
20	140	0.83		110	1.9	85	1.5	1.3										
25	112	0.81		93	1.4	76	1.1	1.2										
30	93	0.77		110	1.4	87	1.1	1.3										
40	70	0.74		117	1.2	111	1.1	1.1										
50	56	0.70		97	0.81	90	0.75	1.1										
65	43	0.67		98	0.66	81	0.55	1.2										
80	35	0.64		91	0.52	65	0.37	1.4										
100	28	0.60		83	0.41	75	0.37	1.1										



6.6

63	$n_1 = 1400$				XA		XC - XF											
	i_n	n_2 [min ⁻¹]	Rd	P_{t0}	T_{2M} [Nm]	P [kW]	T_2 [Nm]	P_1 [kW]	FS'	Input - IEC								
										XC			XF					
	B5/B14			B5			B14											
5	280	0.88	1.8	111	3.7	54	1.8	2.0	90	80	—	90	80	71	90	80	—	
7.5	187	0.87	1.8	120	2.7	80	1.8	1.5										
10	140	0.85	1.6	127	2.2	105	1.8	1.2										
15	93	0.81	1.2	130	1.6	125	1.5	1.1										
20	70	0.80	1.2	144	1.3	120	1.1	1.2										
25	56	0.77	1.0	118	0.90	118	0.9	1.0										
30	47	0.73	0.90	142	0.95	134	0.9	1.1										
40	35	0.69	0.80	150	0.79	142	0.75	1.1										
50	28	0.65	0.70	122	0.55	122	0.55	1.0										
65	22	0.61	0.60	122	0.45	100	0.37	1.2										
80	18	0.58	0.60	113	0.36	79	0.25	1.4										
100	14	0.53	0.50	102	0.28	91	0.25	1.1										



6.6

63	$n_1 = 900$				XA		XC - XF											
	i_n	n_2 [min ⁻¹]	Rd	P_{t0}	T_{2M} [Nm]	P [kW]	T_2 [Nm]	P_1 [kW]	FS'	Input - IEC								
										XC			XF					
	B5/B14			B5			B14											
5	180	0.87	—	135	2.9	69	1.5	1.9	90	80	—	90	80	71	90	80	—	
7.5	120	0.85		144	2.1	102	1.5	1.4										
10	90	0.83		150	1.7	133	1.5	1.1										
15	60	0.79		152	1.2	139	1.1	1.1										
20	45	0.77		167	1.0	123	0.75	1.4										
25	36	0.74		140	0.71	109	0.55	1.3										
30	30	0.70		164	0.74	122	0.55	1.3										
40	23	0.66		171	0.61	154	0.55	1.1										
50	18	0.61		141	0.44	120	0.37	1.2										
65	14	0.57		139	0.35	98	0.25	1.4										
80	11	0.54		128	0.28	115	0.25	1.1										
100	9	0.50		115	0.22	95	0.18	1.2										



6.6

63	$n_1 = 500$				XA		XC - XF											
	i_n	n_2 [min ⁻¹]	Rd	P_{t0}	T_{2M} [Nm]	P [kW]	T_2 [Nm]	P_1 [kW]	FS'	Input - IEC								
										XC			XF					
	B5/B14			B5			B14											
5	100	0.85	—	169	2.08	20	0.25	8.3	90	80	—	90	80	71	90	80	—	
7.5	67	0.83		177	1.5	30	0.25	5.9										
10	50	0.81		182	1.2	39	0.25	4.7										
15	33	0.76		184	0.84	55	0.25	3.4										
20	25	0.74		200	0.70	71	0.25	2.8										
25	20	0.71		165	0.49	85	0.25	1.9										
30	17	0.65		195	0.52	94	0.25	2.1										
40	13	0.62		201	0.43	118	0.25	1.7										
50	10	0.56		165	0.31	135	0.25	1.2										
65	8	0.52		161	0.25	163	0.25	1.0										
80	6	0.50		148	0.19	137	0.18	1.1										
100	5	0.45		122	0.14	77	0.09	1.6										



6.6

* **ATTENZIONE:** la coppia massima utilizzabile $[T_{2M}]$ deve essere calcolata utilizzando il fattore di servizio: $T_{2M} = T_2 \times FS'$

* **WARNING:** Maximum allowable torque $[T_{2M}]$ must be calculated using the following service factor: $T_{2M} = T_2 \times FS'$

* **ACHTUNG:** das max. anwendbare Drehmoment $[T_{2M}]$ muss mit folgendem Betriebsfaktor berechnet werden: $T_{2M} = T_2 \times FS'$



2.5 Dati tecnici

2.5 Technical data

2.5 Technische Daten

75	$n_1 = 2800$				XA		XC - XF											
	i_n	n_2 [min ⁻¹]	Rd	P_{10}	T_{2M} [Nm]	P [kW]	T_2 [Nm]	P_1 [kW]	FS'	Input - IEC								
										XC			XF			B5		
	B5/B14			B5			B14											
Kg 11.0	7.5	373	0.89	—	131	5.8	125	5.5	1.0	112 100	90	—	112 100	90	80	112 100	90	—
	10	280	0.88		143	4.8	120	4	1.2									
	15	187	0.85		152	3.5	131	3	1.2									
	20	140	0.84		172	3.0	171	3	1.0									
	25	112	0.82		155	2.2	154	2.2	1.0									
	30	93	0.78		170	2.1	120	1.5	1.4									
	40	70	0.75		183	1.8	154	1.5	1.2									
	50	56	0.73		166	1.3	136	1.1	1.2									
	65	43	0.69		155	1.0	114	0.75	1.4									
	80	35	0.66		145	0.80	135	0.75	1.1									
100	28	0.62	131	0.62	159	0.75	0.8											

75	$n_1 = 1400$				XA		XC - XF											
	i_n	n_2 [min ⁻¹]	Rd	P_{10}	T_{2M} [Nm]	P [kW]	T_2 [Nm]	P_1 [kW]	FS'	Input - IEC								
										XC			XF			B5		
	B5/B14			B5			B14											
Kg 11.0	7.5	187	0.87	2.5	180	4.0	178	4	1.0	112 100	90	—	112 100	90	80	112 100	90	—
	10	140	0.86	2.3	193	3.3	176	3	1.1									
	15	93	0.83	1.9	202	2.4	187	2.2	1.1									
	20	70	0.81	1.7	226	2.0	199	1.8	1.1									
	25	56	0.78	1.5	202	1.5	200	1.5	1.0									
	30	47	0.74	1.2	220	1.5	167	1.1	1.3									
	40	35	0.71	1.1	235	1.2	213	1.1	1.1									
	50	28	0.67	1.0	211	0.92	206	0.9	1.0									
	65	22	0.63	0.90	195	0.70	154	0.55	1.3									
	80	18	0.60	0.80	182	0.55	180	0.55	1.0									
100	14	0.56	0.70	162	0.43	210	0.55	0.8										

75	$n_1 = 900$				XA		XC - XF											
	i_n	n_2 [min ⁻¹]	Rd	P_{10}	T_{2M} [Nm]	P [kW]	T_2 [Nm]	P_1 [kW]	FS'	Input - IEC								
										XC			XF			B5		
	B5/B14			B5			B14											
Kg 11.0	7.5	120	0.86	—	215	3.1	205	3	1.0	112 100	90	—	112 100	90	80	112 100	90	—
	10	90	0.84		229	2.6	197	2.2	1.2									
	15	60	0.81		237	1.9	231	1.8	1.0									
	20	45	0.78		263	1.6	250	1.5	1.1									
	25	36	0.76		233	1.2	221	1.1	1.1									
	30	30	0.71		254	1.1	249	1.1	1.0									
	40	23	0.67		270	0.94	214	0.75	1.3									
	50	18	0.64		241	0.71	186	0.55	1.3									
	65	14	0.59		221	0.54	151	0.37	1.5									
	80	11	0.56		205	0.43	177	0.37	1.2									
100	9	0.52	184	0.34	203	0.37	0.9											

75	$n_1 = 500$				XA		XC - XF											
	i_n	n_2 [min ⁻¹]	Rd	P_{10}	T_{2M} [Nm]	P [kW]	T_2 [Nm]	P_1 [kW]	FS'	Input - IEC								
										XC			XF			B5		
	B5/B14			B5			B14											
Kg 11.0	7.5	67	0.84	—	265	2.2	90	0.75	2.9	112 100	90	—	112 100	90	80	112 100	90	—
	10	50	0.82		279	1.8	118	0.75	2.4									
	15	33	0.78		286	1.3	167	0.75	1.7									
	20	25	0.75		315	1.1	216	0.75	1.5									
	25	20	0.72		278	0.80	260	0.75	1.1									
	30	17	0.67		302	0.79	288	0.75	1.1									
	40	13	0.63		317	0.66	265	0.55	1.2									
	50	10	0.59		282	0.50	210	0.37	1.3									
	65	8	0.55		257	0.38	251	0.37	1.0									
	80	6	0.52		238	0.30	197	0.25	1.2									
100	5	0.47	206	0.23	161	0.18	1.3											

* **ATTENZIONE:** la coppia massima utilizzabile $[T_{2M}]$ deve essere calcolata utilizzando il fattore di servizio: $T_{2M} = T_2 \times FS'$

* **WARNING:** Maximum allowable torque $[T_{2M}]$ must be calculated using the following service factor: $T_{2M} = T_2 \times FS'$

* **ACHTUNG:** das max. anwendbare Drehmoment $[T_{2M}]$ muss mit folgendem Betriebsfaktor berechnet werden: $T_{2M} = T_2 \times FS'$



2.5 Dati tecnici

2.5 Technical data

2.5 Technische Daten

90	$n_1 = 2800$				XA		XC - XF											
	i_n	n_2 [min ⁻¹]	Rd	P_{10}	T_{2M} [Nm]	P [kW]	T_2 [Nm]	P_1 [kW]	FS'	XC		Input - IEC						
										B5/B14		B5			XF			
Kg 23.6	7.5	373	0.89	—	209	9.2	171	7.5	1.2	112 100	90	—	112 100	90	80	112 100	90	—
	10	280	0.88		223	7.4	165	5.5	1.3									
	15	187	0.86		241	5.5	241	5.5	1.0									
	20	140	0.84		272	4.7	230	4	1.2									
	25	112	0.83		255	3.6	212	3	1.2									
	30	93	0.79		270	3.3	243	3	1.1									
	40	70	0.77		293	2.8	230	2.2	1.3									
	50	56	0.74		278	2.2	278	2.2	1.0									
	65	43	0.71		250	1.6	235	1.5	1.1									
	80	35	0.68		238	1.3	205	1.1	1.2									
100	28	0.64	212	0.97	163	0.75	1.3	—	80									

90	$n_1 = 1400$				XA		XC - XF											
	i_n	n_2 [min ⁻¹]	Rd	P_{10}	T_{2M} [Nm]	P [kW]	T_2 [Nm]	P_1 [kW]	FS'	XC		Input - IEC						
										B5/B14		B5			XF			
Kg 23.6	7.5	187	0.88	3.0	290	6.5	247	5.5	1.2	112 100	90	—	112 100	90	80	112 100	90	—
	10	140	0.86	2.5	305	5.2	236	4	1.3									
	15	93	0.84	2.2	320	3.7	256	3	1.2									
	20	70	0.82	2.0	360	3.2	334	3	1.1									
	25	56	0.80	1.8	332	2.4	299	2.2	1.1									
	30	47	0.76	1.5	350	2.3	340	2.2	1.0									
	40	35	0.72	1.3	377	1.9	355	1.8	1.1									
	50	28	0.69	1.1	353	1.5	353	1.5	1.0									
	65	22	0.65	1.0	317	1.1	317	1.1	1.0									
	80	18	0.63	1.0	309	0.90	309	0.9	1.0									
100	14	0.58	0.80	264	0.67	217	0.55	1.2	—	80								

90	$n_1 = 900$				XA		XC - XF											
	i_n	n_2 [min ⁻¹]	Rd	P_{10}	T_{2M} [Nm]	P [kW]	T_2 [Nm]	P_1 [kW]	FS'	XC		Input - IEC						
										B5/B14		B5			XF			
Kg 23.6	7.5	120	0.86	—	345	5.0	206	3	1.7	112 100	90	—	112 100	90	80	112 100	90	—
	10	90	0.85		362	4.0	270	3	1.3									
	15	60	0.82		377	2.9	286	2.2	1.3									
	20	45	0.79		419	2.5	371	2.2	1.1									
	25	36	0.77		385	1.9	369	1.8	1.0									
	30	30	0.73		416	1.8	416	1.8	1.0									
	40	23	0.69		440	1.5	440	1.5	1.0									
	50	18	0.66		398	1.1	384	1.1	1.0									
	65	14	0.62		358	0.84	319	0.75	1.1									
	80	11	0.59		337	0.68	274	0.55	1.2									
100	9	0.54	313	0.55	313	0.55	1.0	—	80									

90	$n_1 = 500$				XA		XC - XF											
	i_n	n_2 [min ⁻¹]	Rd	P_{10}	T_{2M} [Nm]	P [kW]	T_2 [Nm]	P_1 [kW]	FS'	XC		Input - IEC						
										B5/B14		B5			XF			
Kg 23.6	7.5	67	0.84	—	430	3.6	91	0.75	4.7	112 100	90	—	112 100	90	80	112 100	90	—
	10	50	0.83		443	2.8	118	0.75	3.7									
	15	33	0.79		456	2.0	169	0.75	2.7									
	20	25	0.76		502	1.7	219	0.75	2.3									
	25	20	0.74		459	1.3	265	0.75	1.7									
	30	17	0.68		483	1.2	294	0.75	1.6									
	40	13	0.65		512	1.0	371	0.75	1.4									
	50	10	0.61		467	0.80	439	0.75	1.1									
	65	8	0.57		417	0.59	388	0.55	1.1									
	80	6	0.54		391	0.48	305	0.37	1.3									
100	5	0.49	345	0.37	344	0.37	1.0	—	80									

* **ATTENZIONE:** la coppia massima utilizzabile $[T_{2M}]$ deve essere calcolata utilizzando il fattore di servizio: $T_{2M} = T_2 \times FS'$

* **WARNING:** Maximum allowable torque $[T_{2M}]$ must be calculated using the following service factor: $T_{2M} = T_2 \times FS'$

* **ACHTUNG:** das max. anwendbare Drehmoment $[T_{2M}]$ muss mit folgendem Betriebsfaktor berechnet werden: $T_{2M} = T_2 \times FS'$



2.5 Dati tecnici

2.5 Technical data

2.5 Technische Daten

110	n₁ = 2800				XA		XC - XF											
	i _n	n ₂ [min ⁻¹]	Rd	P ₁₀	T _{2M} [Nm]	P [kW]	T ₂ [Nm]	P ₁ [kW]	FS'	Input - IEC								
										XC			XF					
	B5/B14			B5			B14											
 44.0	7.5	373	0.89	—	345	15.1	343	15	1.0	132	112 100	—	132	112 100	90	132	—	—
	10	280	0.88		368	12.2	332	11	1.1									
	15	187	0.86		404	9.2	331	7.5	1.2									
	20	140	0.85		465	8.0	435	7.5	1.1									
	25	112	0.84		441	6.2	393	5.5	1.1									
	30	93	0.80		459	5.6	450	5.5	1.0									
	40	70	0.78		503	4.7	424	4	1.2									
	50	56	0.76		476	3.7	388	3	1.2									
	65	43	0.73		417	2.6	354	2.2	1.2									
	80	35	0.70		400	2.1	287	1.5	1.4									
100	28	0.66	364	1.6	339	1.5	1.1	—	90	—	—	—	—	—	—	—		

110	n₁ = 1400				XA		XC - XF											
	i _n	n ₂ [min ⁻¹]	Rd	P ₁₀	T _{2M} [Nm]	P [kW]	T ₂ [Nm]	P ₁ [kW]	FS'	Input - IEC								
										XC			XF					
	B5/B14			B5			B14											
 44.0	7.5	187	0.88	4.3	480	10.6	415	9.2	1.2	132	112 100	—	132	112 100	90	132	—	—
	10	140	0.87	4.0	504	8.5	446	7.5	1.1									
	15	93	0.84	3.2	543	6.3	475	5.5	1.1									
	20	70	0.83	3.0	623	5.5	623	5.5	1.0									
	25	56	0.81	2.7	578	4.2	554	4	1.0									
	30	47	0.77	2.2	601	3.8	472	3	1.3									
	40	35	0.74	2.0	650	3.2	606	3	1.1									
	50	28	0.72	1.8	608	2.5	538	2.2	1.1									
	65	22	0.68	1.6	528	1.8	451	1.5	1.2									
	80	18	0.65	1.5	503	1.4	390	1.1	1.3									
100	14	0.61	1.3	458	1.1	458	1.1	1.0	—	90	—	—	—	—	—	—		

110	n₁ = 900				XA		XC - XF											
	i _n	n ₂ [min ⁻¹]	Rd	P ₁₀	T _{2M} [Nm]	P [kW]	T ₂ [Nm]	P ₁ [kW]	FS'	Input - IEC								
										XC			XF					
	B5/B14			B5			B14											
 44.0	7.5	120	0.87	—	578	8.3	381	5.5	1.5	132	112 100	—	132	112 100	90	132	—	—
	10	90	0.86		600	6.6	500	5.5	1.2									
	15	60	0.83		641	4.9	526	4	1.2									
	20	45	0.81		720	4.2	685	4	1.1									
	25	36	0.79		672	3.2	628	3	1.1									
	30	30	0.74		697	2.9	520	2.2	1.3									
	40	23	0.71		749	2.5	664	2.2	1.1									
	50	18	0.68		697	1.9	653	1.8	1.1									
	65	14	0.64		603	1.4	487	1.1	1.2									
	80	11	0.61		571	1.1	570	1.1	1.0									
100	9	0.57	513	0.85	450	0.75	1.1	—	90	—	—	—	—	—	—	—		

110	n₁ = 500				XA		XC - XF											
	i _n	n ₂ [min ⁻¹]	Rd	P ₁₀	T _{2M} [Nm]	P [kW]	T ₂ [Nm]	P ₁ [kW]	FS'	Input - IEC								
										XC			XF					
	B5/B14			B5			B14											
 44.0	7.5	67	0.85	—	718	5.9	183	1.5	3.9	132	112 100	—	132	112 100	90	132	—	—
	10	50	0.84		738	4.6	240	1.5	3.1									
	15	33	0.80		778	3.4	344	1.5	2.3									
	20	25	0.78		866	2.9	446	1.5	1.9									
	25	20	0.76		802	2.2	542	1.5	1.5									
	30	17	0.70		832	2.1	603	1.5	1.4									
	40	13	0.67		886	1.7	765	1.5	1.2									
	50	10	0.64		820	1.3	671	1.1	1.2									
	65	8	0.59		705	0.96	553	0.75	1.3									
	80	6	0.56		664	0.77	643	0.75	1.0									
100	5	0.52	594	0.60	542	0.55	1.1	—	90	—	—	—	—	—	—	—		

* **ATTENZIONE:** la coppia massima utilizzabile [T_{2M}] deve essere calcolata utilizzando il fattore di servizio: T_{2M} = T₂ x FS'

* **WARNING:** Maximum allowable torque [T_{2M}] must be calculated using the following service factor: T_{2M} = T₂ x FS'

* **ACHTUNG:** das max. anwendbare Drehmoment [T_{2M}] muss mit folgendem Betriebsfaktor berechnet werden: T_{2M} = T₂ x FS'

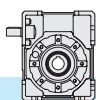

2.5 Dati tecnici

2.5 Technical data

2.5 Technische Daten

130	$n_1 = 2800$				XA		XC - XF									
	i_n	n_2 [min ⁻¹]	Rd	P_{10}	T_{2M} [Nm]	P [kW]	T_2 [Nm]	P_1 [kW]	FS'	XC			Input - IEC			
										XF			XF			
	B5/B14			B5			B14									
Kg 55.0	7.5	373	0.90	—	530	23	345	15	1.5	132	112 100	—	132	112 100	90	—
	10	280	0.89		549	18.1	455	15	1.2							
	15	187	0.87		636	14.3	490	11	1.3							
	20	140	0.86		733	12.5	645	11	1.1							
	25	112	0.85		710	9.8	667	9.2	1.1							
	30	93	0.81		729	8.8	622	7.5	1.2							
	40	70	0.80		819	7.5	819	7.5	1.0							
	50	56	0.78		758	5.7	732	5.5	1.0							
	65	43	0.75		648	3.9	499	3	1.3							
	80	35	0.73		637	3.2	598	3	1.1							
100	28	0.70	597	2.5	525	2.2	1.1									

130	$n_1 = 1400$				XA		XC - XF									
	i_n	n_2 [min ⁻¹]	Rd	P_{10}	T_{2M} [Nm]	P [kW]	T_2 [Nm]	P_1 [kW]	FS'	XC			Input - IEC			
										XF			XF			
	B5/B14			B5			B14									
Kg 55.0	7.5	187	0.89	6.0	736	16.2	418	9.2	1.8	132	112 100	—	132	112 100	90	—
	10	140	0.88	5.5	756	12.6	552	9.2	1.4							
	15	93	0.85	4.4	855	9.8	803	9.2	1.1							
	20	70	0.84	4.1	974	8.5	860	7.5	1.1							
	25	56	0.83	3.9	920	6.5	778	5.5	1.2							
	30	47	0.79	3.2	947	5.9	883	5.5	1.1							
	40	35	0.76	2.8	1037	5.0	829	4	1.3							
	50	28	0.74	2.6	959	3.8	757	3	1.3							
	65	22	0.71	2.3	801	2.6	678	2.2	1.2							
	80	18	0.68	2.1	758	2.1	649	1.8	1.2							
100	14	0.64	1.8	699	1.6	655	1.5	1.1								

130	$n_1 = 900$				XA		XC - XF									
	i_n	n_2 [min ⁻¹]	Rd	P_{10}	T_{2M} [Nm]	P [kW]	T_2 [Nm]	P_1 [kW]	FS'	XC			Input - IEC			
										XF			XF			
	B5/B14			B5			B14									
Kg 55.0	7.5	120	0.88	—	889	12.7	385	5.5	2.3	132	112 100	—	132	112 100	90	—
	10	90	0.87		905	9.8	508	5.5	1.8							
	15	60	0.84		1016	7.6	735	5.5	1.4							
	20	45	0.82		1149	6.6	957	5.5	1.2							
	25	36	0.81		1074	5.0	860	4	1.3							
	30	30	0.76		1113	4.6	968	4	1.2							
	40	23	0.73		1208	3.9	930	3	1.3							
	50	18	0.70		1077	2.9	817	2.2	1.3							
	65	14	0.67		924	2.0	832	1.8	1.1							
	80	11	0.64		869	1.6	815	1.5	1.1							
100	9	0.60	828	1.3	700	1.1	1.2									

130	$n_1 = 500$				XA		XC - XF									
	i_n	n_2 [min ⁻¹]	Rd	P_{10}	T_{2M} [Nm]	P [kW]	T_2 [Nm]	P_1 [kW]	FS'	XC			Input - IEC			
										XF			XF			
	B5/B14			B5			B14									
Kg 55.0	7.5	67	0.86	—	1109	9.0	228	1.85	4.9	132	112 100	—	132	112 100	90	—
	10	50	0.84		1107	6.9	297	1.85	3.7							
	15	33	0.81		1230	5.3	429	1.85	2.9							
	20	25	0.79		1388	4.6	558	1.85	2.5							
	25	20	0.78		1266	3.4	689	1.85	1.8							
	30	17	0.72		1320	3.2	763	1.85	1.7							
	40	13	0.69		1423	2.7	975	1.85	1.5							
	50	10	0.66		1261	2.0	1166	1.85	1.1							
	65	8	0.63		1095	1.4	860	1.10	1.3							
	80	6	0.59		1082	1.2	992	1.10	1.1							
100	5	0.55	945	0.9	788	0.75	1.2									

* **ATTENZIONE:** la coppia massima utilizzabile $[T_{2M}]$ deve essere calcolata utilizzando il fattore di servizio: $T_{2M} = T_2 \times FS'$

* **WARNING:** Maximum allowable torque $[T_{2M}]$ must be calculated using the following service factor: $T_{2M} = T_2 \times FS'$



* **ACHTUNG:** das max. anwendbare Drehmoment $[T_{2M}]$ muss mit folgendem Betriebsfaktor berechnet werden: $T_{2M} = T_2 \times FS'$









2.6 **Momenti d'inerzia** [Kg·cm²]
(riferiti all'albero veloce in entrata)

2.6 **Moments of inertia** [Kg·cm²]
(referred to input shaft)

2.6 **Trägheitsmoment** [Kg·cm²]
(bez. Antriebswelle)

X30	i_n	XA 	XC 		XF 	
			B5 - B14		B5 - B14	
			IEC 56	IEC 63	IEC 56	IEC 63
5	0.077	0.130	0.127	0.122	0.123	
7.5	0.058	0.112	0.109	0.102	0.103	
10	0.049	0.103	0.100	0.093	0.094	
15	0.042	0.097	0.094	0.087	0.087	
20	0.039	0.095	0.092	0.084	0.084	
25	0.038	0.094	0.091	0.083	0.083	
30	0.038	0.093	0.090	0.083	0.084	
40	0.037	0.093	0.090	0.082	0.082	
50	0.037	0.092	0.089	0.081	0.082	
65	0.024	0.079	-	0.069	0.069	
80	0.024	0.079	-	0.069	0.069	
100	0.024	0.078	-	0.069	0.069	

X40	i_n	XA 	XC 			XF 		
			B5 - B14			B5	B5 - B14	
			IEC 56	IEC 63	IEC 71	IEC 56	IEC 63	IEC 71
5	0.242	-	0.391	0.463	0.289	0.447	0.464	
7.5	0.170	-	0.321	0.356	0.217	0.375	0.391	
10	0.144	-	0.272	0.347	0.190	0.348	0.365	
15	0.125	-	0.266	0.340	0.171	0.329	0.346	
20	0.094	-	0.263	0.338	0.141	0.298	0.315	
25	0.091	-	0.262	0.337	0.137	0.295	0.312	
30	0.113	-	0.262	0.337	0.160	0.318	0.335	
40	0.087	-	0.261	-	0.134	0.292	0.309	
50	0.087	0.182	0.261	-	0.133	0.291	0.308	
65	0.069	0.182	0.261	-	0.116	0.274	0.290	
80	0.069	0.182	0.261	-	0.115	0.273	0.290	
100	0.068	0.182	0.261	-	0.115	0.273	0.290	

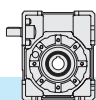

X50	i_n	XA 	XC 			XF 		
			B5 - B14			B5	B5 - B14	
			IEC 63	IEC 71	IEC 80	IEC 63	IEC 71	IEC 80
5	0.744	-	0.922	1.046	0.978	0.955	1.558	
7.5	0.499	-	0.684	0.935	0.733	0.750	1.313	
10	0.417	-	0.602	0.853	0.651	0.668	1.231	
15	0.358	-	0.543	0.794	0.593	0.609	1.173	
20	0.281	-	0.523	0.774	0.516	0.532	1.096	
25	0.272	-	0.513	0.764	0.506	0.523	1.086	
30	0.323	-	0.508	0.759	0.557	0.574	1.137	
40	0.262	0.315	0.503	-	0.496	0.513	1.076	
50	0.183	0.313	0.501	-	0.417	0.434	0.997	
65	0.136	0.311	0.499	-	0.370	0.387	0.950	
80	0.136	0.310	0.498	-	0.370	0.387	0.950	
100	0.135	0.309	0.498	-	0.370	0.386	0.950	









2.6 **Momenti d'inerzia** [Kg·cm²]
(riferiti all'albero veloce in entrata)

2.6 **Moments of inertia** [Kg·cm²]
(referred to input shaft)

2.6 **Trägheitsmoment** [Kg·cm²]
(bez. Antriebswelle)

X63	i_n	XA 	XC 			XF 		
			B5 - B14			B5	B5 - B14	
			IEC 71	IEC 80	IEC 90	IEC 71	IEC 80	IEC 90
5	1.853	-	2.431	2.671	2.632	2.766	3.844	
7.5	1.363	-	1.949	2.269	2.142	2.276	3.354	
10	1.158	-	1.744	2.063	1.936	2.070	3.148	
15	1.011	-	1.597	1.916	1.789	1.924	3.001	
20	0.710	-	1.545	1.864	1.489	1.623	2.701	
25	0.679	-	1.514	1.833	1.458	1.592	2.670	
30	0.922	-	1.508	1.828	1.701	1.835	2.913	
40	0.660	0.966	1.495	-	1.439	1.573	2.651	
50	0.653	0.959	1.488	-	1.431	1.565	2.643	
65	0.552	0.955	1.484	-	1.330	1.465	2.542	
80	0.550	0.953	1.482	-	1.329	1.463	2.541	
100	0.549	0.952	1.481	-	1.327	1.462	2.539	

X75	i_n	XA 	XC 			XF 		
			B5 - B14			B5	B5 - B14	
			IEC 80	IEC 90	IEC 100-112	IEC 80	IEC 90	IEC 100-112
7.5	2.970	-	3.712	4.462	5.138	5.066	6.837	
10	2.492	-	3.234	3.984	4.661	4.588	6.359	
15	2.151	-	2.893	3.643	4.320	4.247	6.018	
20	1.567	-	2.774	3.523	3.735	3.662	5.433	
25	1.501	-	2.709	3.458	3.670	3.597	5.368	
30	1.946	-	2.689	3.438	4.115	4.042	5.813	
40	1.451	1.595	2.659	-	3.620	3.547	5.318	
50	1.435	1.578	2.642	-	3.603	3.531	5.302	
65	1.158	1.569	2.633	-	3.326	3.253	5.024	
80	1.153	1.565	2.629	-	3.322	3.249	5.020	
100	1.150	1.562	2.626	-	3.318	3.246	5.017	

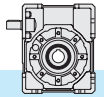

X90	i_n	XA 	XC 			XF 		
			B5 - B14			B5	B5 - B14	
			IEC 80	IEC 90	IEC 100-112	IEC 80	IEC 90	IEC 100-112
7.5	6.167	-	6.898	7.671	8.335	8.263	10.033	
10	5.143	-	5.875	6.648	7.312	7.239	9.010	
15	4.413	-	5.144	5.917	6.581	6.508	8.279	
20	2.653	-	3.398	5.661	4.821	4.749	6.519	
25	2.511	-	3.256	5.520	4.680	4.607	6.378	
30	3.974	-	3.215	5.479	6.142	6.070	7.841	
40	2.406	-	3.151	-	4.574	4.502	6.273	
50	2.371	-	3.115	-	4.539	4.467	6.237	
65	1.672	2.024	3.096	-	3.841	3.768	5.539	
80	1.663	2.014	3.087	-	3.831	3.759	5.530	
100	1.656	2.008	3.080	-	3.825	3.752	5.523	





2.6 **Momenti d'inerzia** [Kg·cm²]
(riferiti all'albero veloce in entrata)

2.6 **Moments of inertia** [Kg·cm²]
(referred to input shaft)

2.6 **Trägheitsmoment** [Kg·cm²]
(bez. Antriebswelle)

X110	i_n	XA 	XC 			XF 			
			B5 - B14			B5			B5 - B14
			IEC 90	IEC 100-112	IEC 132	IEC 80	IEC 90	IEC 100-112	
			7.5	16.247	-	17.980	20.038	20.584	20.535
10	13.386	-	15.119	17.177	17.723	17.674	17.851	19.843	
15	11.343	-	13.076	15.134	15.679	15.631	15.807	17.799	
20	6.655	-	8.367	14.418	10.992	10.943	11.120	13.112	
25	6.257	-	7.969	14.020	10.594	10.545	10.722	12.714	
30	10.117	-	11.850	13.908	14.453	14.405	14.581	16.573	
40	5.965	-	7.677	-	10.302	10.254	10.430	12.422	
50	5.866	-	7.578	-	10.203	10.154	10.330	12.323	
65	3.792	5.592	7.510	-	8.128	8.080	8.256	10.248	
80	3.770	5.570	7.489	-	8.107	8.059	8.235	10.227	
100	3.755	5.555	7.474	-	8.092	8.044	8.220	10.212	

X130	i_n	XA 	XC 			XF 		
			B5 - B14			B5		
			IEC 90	IEC 100-112	IEC 132	IEC 90	IEC 100-112	IEC 132
			7.5	42.80	-	40.70	42.78	48.92
10	35.06	-	32.96	35.04	41.18	41.48	42.27	
15	29.53	-	27.43	29.51	35.66	35.96	36.74	
20	18.95	-	16.68	27.58	25.07	25.37	26.16	
25	17.80	-	15.52	26.42	23.92	24.22	25.00	
30	26.22	-	24.12	26.20	32.34	32.64	33.42	
40	17.09	-	14.81	25.71	23.21	23.51	24.29	
50	16.80	-	12.57	-	22.92	23.22	24.00	
65	12.53	10.46	14.35	-	18.66	18.96	19.74	
80	12.48	10.41	14.30	-	18.60	18.90	19.68	
100	12.44	10.37	14.26	-	18.56	18.86	19.65	

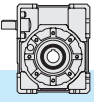

2.7 Dimensioni

2.7 Dimensions

2.7 Abmessungen

XA

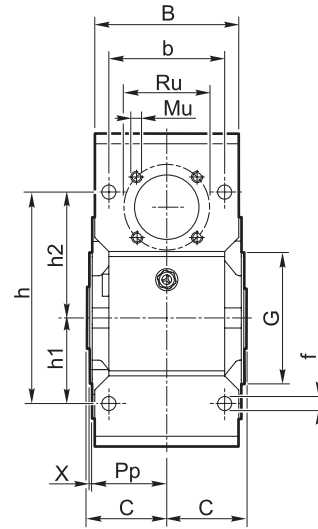
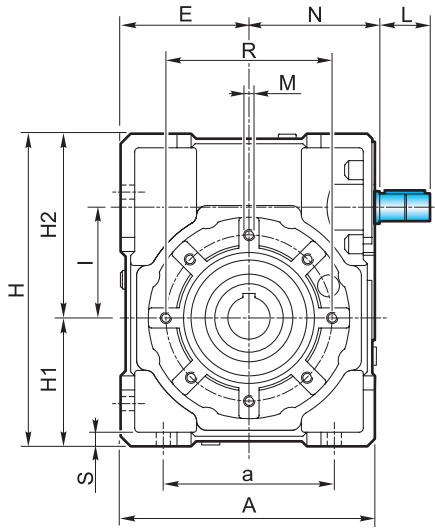

XF

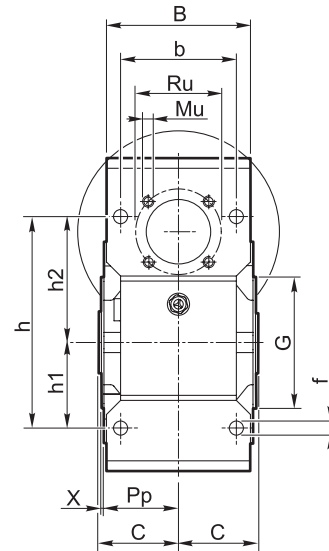
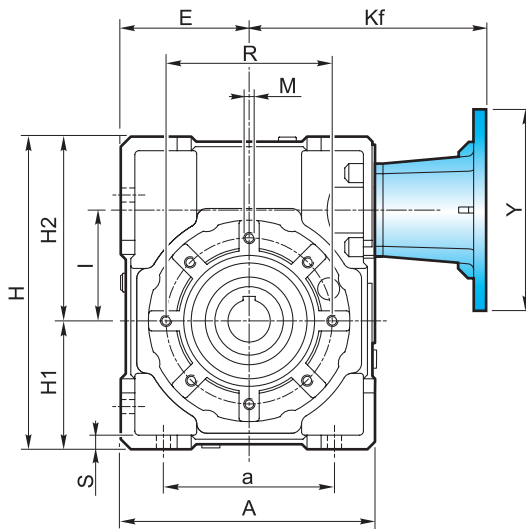

XC

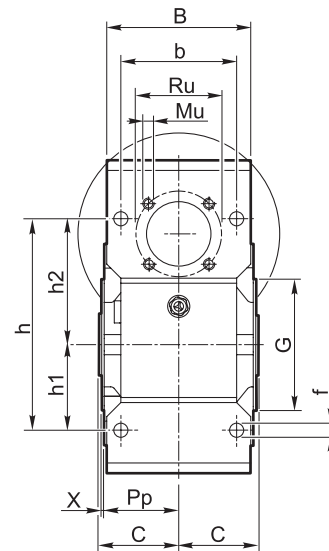
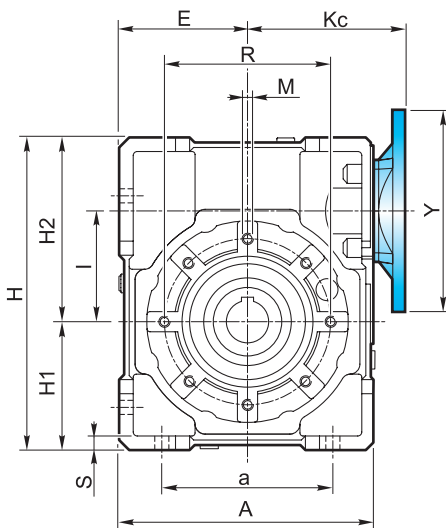

2.7 Dimensioni

2.7 Dimensions

2.7 Abmessungen

Flangia pendolare / Shaft-mounted flange / Aufsteckflansch

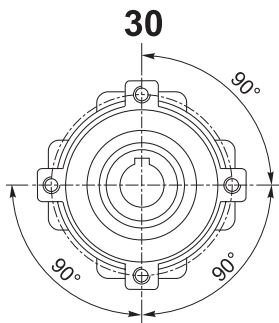

4 Fori / Holes / Bohrungen

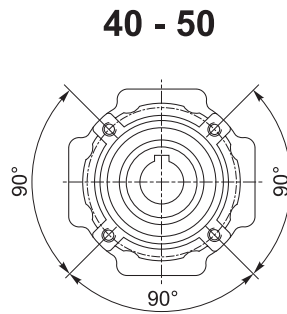

4 Fori / Holes / Bohrungen

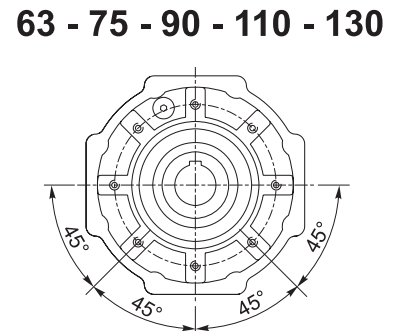

8 Fori / Holes / Bohrungen

Albero uscita cavo
Output hollow shaft
Abtriebshohlwelle

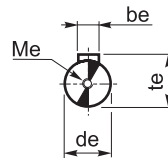
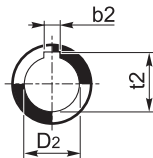

Albero entrata
Input shaft
Antriebswelle

X	A	a	B	b	b _e	b ₂	C	d _e j ₆	D ₂ H ₈	E	f	G h ₈	H	H ₁	H ₂	h	h ₁	h ₂		
30	80	54	56	44	3	5	—	31.5	9	14	—	40	6.5	55	97	40	57	71	27	44
40	105	70	71	60	4	6	6	39	11	18	19	50	6.5	60	125	50	75	90	35	55
50	125	80	85	70	5	8	8	46	14	25	24	60	8.5	70	150	60	90	104	40	64
63	147	100	103	85	6	8	—	56	19	25	—	72	9	80	182	72	110	130	50	80
75	176	120	112	90	8	8	8	60	24	28	30	86	11	95	219.5	86	133.5	153	60	93
90	203	140	130	100	8	10	—	70	24	35	—	103	13	110	248.5	103	145.5	172	70	102
110	252.5	170	143	115	8	12	—	77.5	28	42	—	127.5	14	130	310.5	127.5	183	210	85	125
130	292.5	200	155	120	10	14	14	85	38	45	48	147.5	15	180	355	147.5	207.5	240	100	140

X	I	K _c	K _f	L	M	M _e	M _u	N	P _p	R	Ru	S	t _e	t ₂	X	
30	31.5	57	vedi pag. see page siehe S. 34	15	M6x8	M4x10	M5x7.5	44.5	29	65	35.4	5.5	10.2	16.3	—	1.5
40	40	75		20	M6x10	M4x12	M5x10	57.5	36.5	75	42.4	6	12.5	20.8	21.8	1.5
50	50	82		25	M8x10	M5x13	M6x10	67.5	43.5	85	53.7	7	16	28.3	27.3	1.5
63	63	95		30	M8x14	M8x20	M6x12	77.5	53	95	60.8	8	21.5	28.3	—	2
75	75	112		40	M8x14	M8x20	M8x12	95	57	115	70.7	10	27	31.3	33.3	2
90	90	122		40	M10x18	M8x20	M8x14	105	67	130	70.7	12	27	38.3	—	2
110	110	153		50	M10x18	M8x20	M10x18	130	74	165	85.0	14	31	45.3	—	2.5
130	130	173		70	M12x20	M10x25	M10x16	152	81	215	104	15	41	48.8	51.8	3



2.7 Dimensioni

2.7 Dimensions

2.7 Abmessungen

Flangia uscita / Output flange / Abtriebsflansch

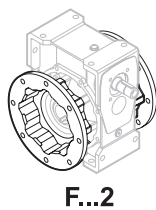
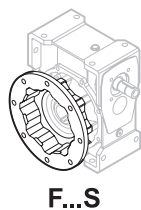
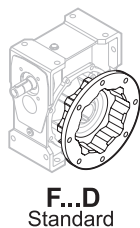
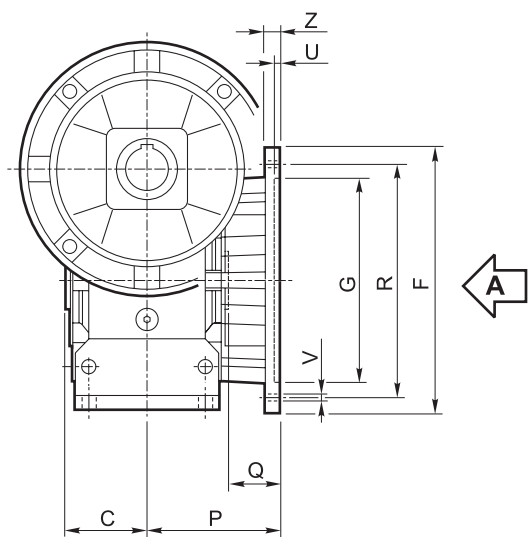

Vista da A / View from A / Ansicht von A

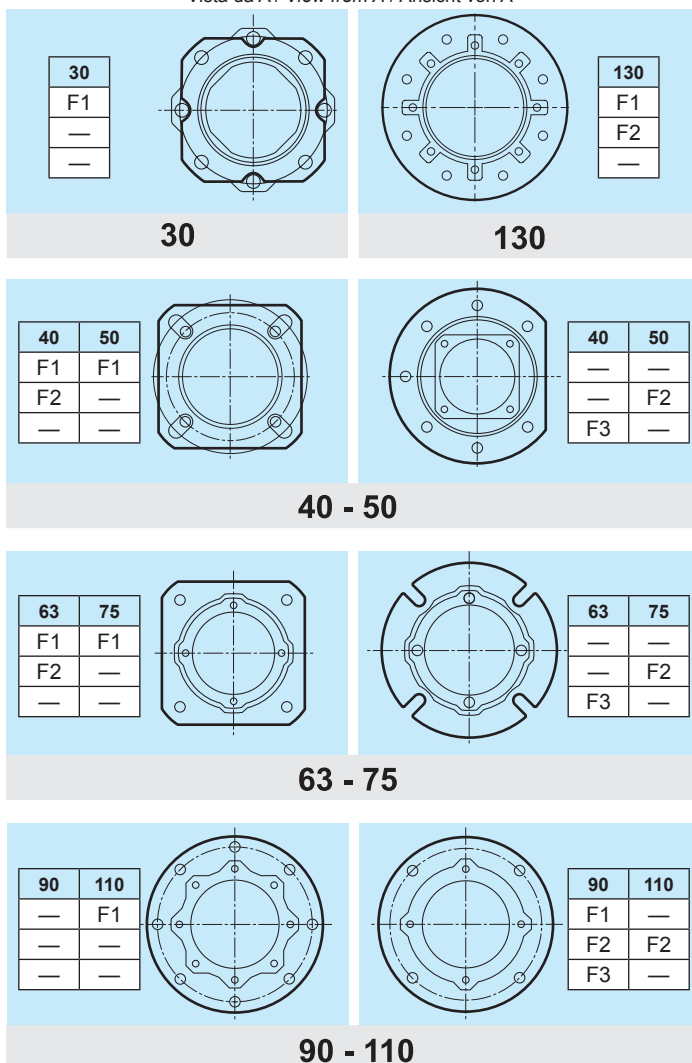

Tipo Type Typ	C	F		G H8	P	Q	R	U	V			Z	
											Ø		
30	31.5		66	50	54.5	23	68	4	n° 4		6.5	6	
													F1
													F2
40	39		85	60	67	28	75-90	4	n° 4		9	8	
													F1
													F2
50	46		94	70	90	44	85-100	5	n° 4		11	10	
													F1
													F2
63	56		142	115	82	26	150	5	n° 4		11	11	
													F1
													F2
75	60		160	130	111	51	165	5	n° 4		13	12	
													F1
													F2
90	70		200	152	111	41	175	5	n° 4		13	12	
													F1
													F2
110	77.5		260	170	131	53.5	230	6	n° 4		13	15	
													F1
													F2
130	85		320	180	140	55	255	7	n° 8 *		16	16	
													F1
													F2

* Foratura ruotata di 22.5°

* Drilling turned of 22.5°

* Durchbohrung 22.5° versetzt



2.7 Dimensioni

2.7 Dimensions

2.7 Abmessungen

Flangia entrata / Input flange / Antriebsflansch

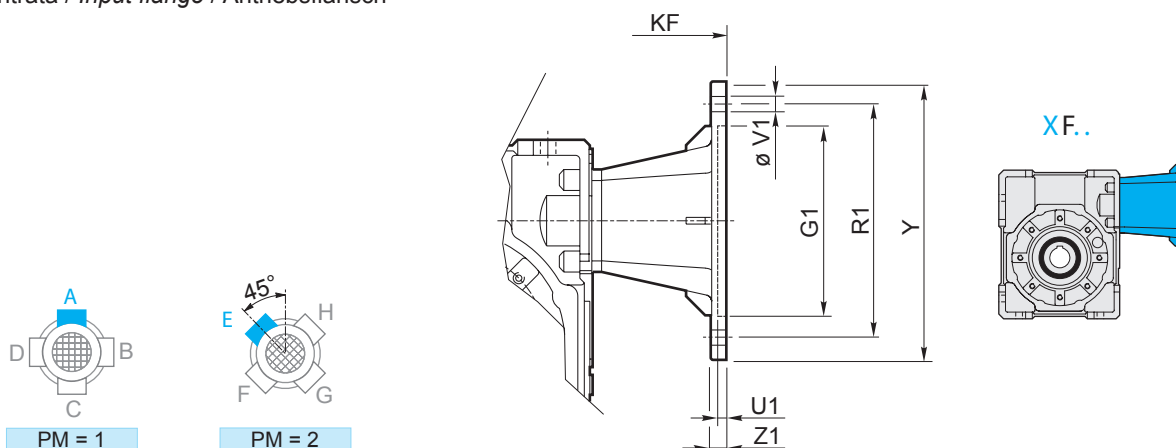

XF	IEC	PM		G ₁	K _F	V ₁						Y	Z ₁
		1	2			R ₁	U ₁	Ø					
30	56 B5	•	•	80	82.5	100	3.5	7			8	120	8
	56 B14		•	50	82.5	65	3.5	6			4	80	8
	63 B5	•	•	95	85.5	115	4	9			8	140	10
	63 B14	•	•	60	85.5	75	3.5	6			8	90	8
40	56 B5	•	•	80	101.5	100	3.5	7			8	120	8
	63 B5	•	•	95	104.5	115	4	9			8	140	10
	63 B14	•	•	60	104.5	75	3.5	6			8	90	8
	71 B5	•	•	110	111.5	130	4.5	9			8	160	10
	71 B14	•	•	70	111.5	85	4	7			8	105	10
50	63 B5	•	•	95	119.5	115	4	9			8	140	10
	71 B5	•	•	110	126.5	130	4.5	9			8	160	10
	71 B14		•	70	126.5	85	3.5	7			4	105	10
	80 B5	•	•	130	136.5	165	4.5	11			8	200	10
	80 B14	•	•	80	136.5	100	4	7			8	120	10
63	71 B5	•	•	110	141.5	130	4.5	9			8	160	10
	80/90 B5	•	•	130	161.5	165	4.5	11			8	200	10
	80 B14	•	•	80	151.5	100	4	7			8	120	10
	90 B14	•	•	95	161.5	115	4	9			8	140	10
75	80/90 B5	•	•	130	190	165	4.5	11			8	200	10
	90 B14		•	95	190	115	4	9			4	140	10
	100/112 B5	•	•	180	200	215	5	14			8	250	14
	100/112 B14	•	•	110	200	130	4.5	9			8	160	10
90	80/90 B5	•	•	130	200	165	4.5	11			8	200	10
	90 B14		•	95	200	115	4	9			4	140	10
	100/112 B5	•	•	180	210	215	5	14			8	250	14
	100/112 B14	•	•	110	210	130	4.5	9			8	160	10
110	80/90 B5	•		130	235	165	4.5	11	4			200	12
	100/112 B5	•		180	245	215	5	14	4			250	14
	132 B5	•		230	266	265	5	14	4			300	16
	132 B14	•		130	266	165	4.5	11	4			200	12
130	90 B5	•		130	281	165	4.5	M10	4			200	12
	100/112 B5	•		180	289	215	5	13	4			250	16
	132 B5	•		230	310	265	5	13	4			300	20

N.B.: Il montaggio STD di P_M=2 solo quando non è possibile il montaggio STD di P_M=1.

N.B.: STD mounting of P_M=2 only if STD mounting of P_M=1 is not possible.

ANMERKUNG: STD Montage von P_M=2 nur wenn STD Montage von P_M=1 unmöglich ist.

2.8 Entrata supplementare (vite bisporgente)

2.8 Additional input (double extended shaft)

2.8 Zusatzantrieb (beidseitige Welle)

S.e.A.

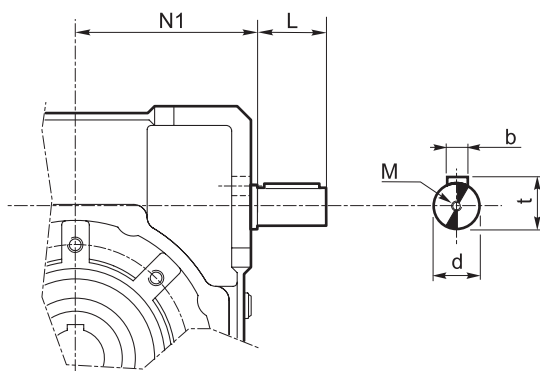

X	d j6	L	M	N1	b	t
30	9	15	M4x10	42.5	3	10.2
40	11	20	M4x12	52.5	4	12.5
50	14	25	M5x13	62.5	5	16
63	19	30	M8x20	74.5	6	21.5
75	24	40	M8x20	91	8	27
90	24	40	M8x20	108	8	27
110	28	50	M8x20	132.5	8	31
130	38	70	M10x25	152	10	41

2.9 Limitatore di coppia cavo passante

2.9 Torque limiter with through hollow shaft

2.9 Drehmomentbegrenzer mit durchgehender Hohlwelle

Il limitatore di coppia viene consigliato in tutte quelle applicazioni che richiedono una limitazione sulla coppia trasmissibile per proteggere l'impianto e/o preservare il riduttore evitando sovraccarichi o urti indesiderati quanto inaspettati.

È un dispositivo con albero dotato di cavo passante, con funzionamento a frizione, ed è integrato al riduttore, presentando un ingombro limitato.

Concepito per lavorare a bagno d'olio, il dispositivo risulta affidabile nel tempo ed è esente da usura se non viene mantenuto in condizioni prolungate di slittamento (condizione che si verifica quando la coppia presenta valori superiori a quelli di taratura).

La taratura è facilmente regolabile dall'esterno attraverso il serraggio di una ghiera autobloccante che porta a compressione le 4 molle a tazza disposte tra loro in serie.

Il dispositivo non consente:

- l'impiego di cuscinetti a rulli conici in uscita
- funzionamento prolungato in condizioni di slittamento.

Nella tabella seguente vengono riportati i valori delle coppie di slittamento M_{2S} in funzione del n° di giri della ghiera.

I valori di taratura presentano una tolleranza del $\pm 10\%$ e si riferiscono ad una condizione statica.

In condizioni dinamiche è da notare che la coppia di slittamento assume valori diversi a seconda del tipo e/o modalità in cui si verifica il sovraccarico: con valori maggiori in caso di carico uniformemente crescente rispetto a valori più contenuti in seguito al verificarsi di picchi improvvisi di carico.

NOTA: quando si supera il valore di taratura si ha slittamento.

Il coefficiente di attrito tra le superfici di contatto da statico diventa dinamico e la coppia trasmessa cala del 30% circa.

È quindi opportuno prevedere uno stop per poter ripartire al valore di taratura iniziale.

The use of a torque limiter is advised when the application requires the limitation of the transmissible torque to safeguard the plant and/or to prevent from unexpected and undesired overloads or shocks which might damage the gearbox.

The torque limiter is a device equipped with through hollow shaft and a friction clutch. It is integrated with the gearbox, therefore the space requirement is limited.

Designed to work in oil bath, the device is reliable over time and is not subject to wear unless kept under conditions of prolonged slipping (it occurs when the torque values are higher than the calibration values).

Calibration can be easily adjusted from outside by tightening the self-locking ring nut which causes the compression of the 4 Belleville washers arranged in series.

The device does not go together with:

- the use of tapered roller bearings at output
- Prolonged operation under slipping conditions.

The following table shows the values of M_{2S} slipping torques depending on the number of revolutions of the ring nut.

Calibration values feature a $\pm 10\%$ tolerance and refer to static conditions.

Under dynamic conditions, the values of the slipping torque differ depending to the type of overload: the values are higher if the load increase is uniform, the values are lower if sudden load peaks occur.

NOTE: *Slipping occurs when the setting values are exceeded.*

The friction coefficient between the contact surfaces from static becomes dynamic and the transmitted torque is approx. 30% lower.

It is advisable to have a stop first in order to have a restart based on the initial setting value.

Die Anwendung eines Drehmomentbegrenzers wird empfohlen, um die Anlage und/oder das Getriebe gegen ungewünschte und unerwartete Überbelastungen oder Stöße zu schützen.

Der Begrenzer verfügt über eine Welle mit durchgehende Hohlwelle und eine Kupplung. Er ist in dem Getriebe integriert, d.h. der Raumbedarf ist klein.

Der Drehmomentbegrenzer wurde für Betrieb in einem Ölbad entworfen. Er ist zuverlässig über Zeit und verschleissfest (außer wenn Rutschen für lange Zeit besteht: das passiert, wenn das Drehmoment höher als der Eichwert ist).

Die Einstellung darf mühelos von außen durch das Anziehen einer selbstsperrenden Mutter ausgeführt werden.

Das Anziehen verursacht die Zusammendrückung der 4 wechelsinniggeschichteten Tellerfeder.

Der Begrenzer sieht das folgende nicht vor:

- die Verwendung von Kegelrollenlager am Abtrieb
- Längerer Rutschbetrieb.

Die nachstehende Tabelle zeigt die Werte der Rutschmomente M_{2S} abhängig von der Zahl der Umdrehungen der Mutter.

Die Eichwerte weisen $\pm 10\%$ Toleranz auf und beziehen sich auf statische Bedingungen.

Unter dynamischen Bedingungen hat das Rutschmoment verschiedene Werte je nach Art der Überbelastung. Die Werte sind höher, wenn die Belastung gleichmäßig zunimmt; sie sind niedriger im Falle von plötzlichen Belastungsspitzen.

BEMERKUNG: Rutschen tritt auf, wenn die eingestellten Werte überschritten werden. Der Reibungskoeffizient zwischen den Berührungsfleichen wird dynamisch anstatt statisch und das übertragene Drehmoment sinkt um ca. 30%.

Es ist daher ratsam, vor dem erneuten Anfahren anzuhalten, um die ursprünglichen Drehmomentwerte zu erreichen.

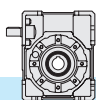

E' importante notare che la coppia di slittamento non resta sempre la medesima durante tutta la vita del limitatore.

Tende infatti a diminuire in rapporto al numero e alla durata degli slittamenti che, rodando le superfici di contatto, ne aumentano il rendimento.

È quindi opportuno verificare periodicamente, soprattutto durante la fase di rodaggio, la taratura del dispositivo.

Là dove sia richiesto un errore più contenuto nella taratura, è necessario testare la coppia trasmissibile sull' impianto.

Il dispositivo viene consegnato tarato alla coppia riportata a catalogo T_{2M} salvo diversa indicazione espressa in fase di ordinazione.

It is important to note that the slipping torque is not the same for the entire life of the torque limiter. It usually decreases in connection with the number and the duration of slippings, this is due to the surface of the torque limiter becoming more engaged, therefore increasing the efficiency.

For this reason it is advisable to check the calibration of the device at regular intervals, specially during the running-in period. Should a smaller calibration error be required, it is necessary to test the transmissible torque on the plant.

The torque limiter is supplied already calibrated at the torque value T_{2M} , unless otherwise specified in the order.

Es ist wichtig zu beachten, dass das Rutschmoment der Rutschkupplung über die gesamte Lebensdauer nicht konstant bleibt, sondern üblicherweise in Verbindung mit längeren Rutschzyklen aufgrund der eingelaufenen Berührungsflächen abnimmt.

Deswegen ist es ratsam, die Einstellung der Vorrichtung besonders während der Einlaufzeit in regelmäßigen Zeitabständen zu prüfen.

Wenn der Drehmomentbegrenzer geliefert wird, ist dieser schon auf dem im Katalog unter T_{2M} angegebenen Wert eingestellt, außer wenn es in der Bestellung anders angegeben wird.

X	N°. giri della ghiera di regolazione / N°. revolutions of ring nut / Nr. Umdrehungen der Mutter															
	3/4	1	1 1/4	1 1/2	1 3/4	2	2 1/4	2 1/2	2 3/4	3	3 1/4	3 1/2	3 3/4	4	4 1/4	4 1/2
	M_{2S} [Nm]															
30		15	18	22	27	32										
40	23	30	35	40	45	50	60									
50		45	60	70	80	90	100	110								
63			80	90	100	110	120	130	140	150	160	170	180	190	200	
75		140	160	180	200	220	240	260	280	300						
90						230	280	310	330	350	380	410	435	460	490	510
110		420	500	560	670	730	810	910								
130																

Disposizione delle molle
Washers' arrangement
Lage der Feder

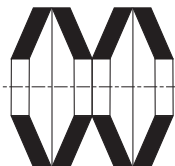

IN SERIE (min. coppia, max. sensibilità)
SERIES (min. torque, max sensitivity)
SERIE (min. Moment, max. Empfindlichkeit)

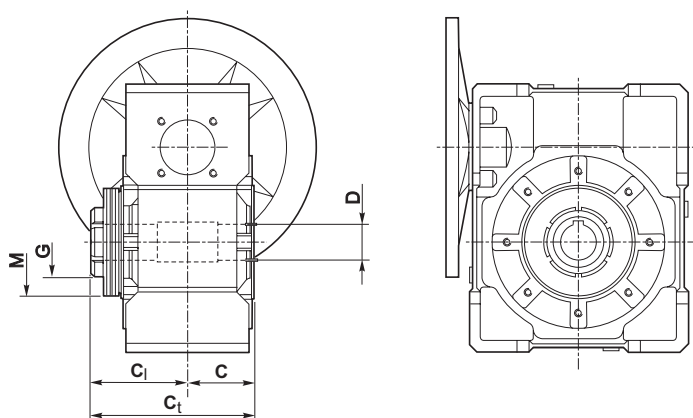

X	C	C ₁	C ₂	D _{H8}	M	G
30	31.5	55.5	87	14	50x25.4x1.25	M25x1.5
40	39	65	104	18 (19)	56x30.5x1.5	M30x1.5
50	46	76	122	25 (24)	63x40.5x1.8	M40x1.5
63	56	91	147	25	71x40.5x2	M40x1.5
75	60	100	160	28 (30)	90x50.5x2.5	M50x1.5
90	70	109	179	35 (32)	100x51x2.7	M50x1.5
110	77.5	127.5	205	42	125x61x4	M60x2.0
130						

() A richiesta / On request / Auf Anfrage

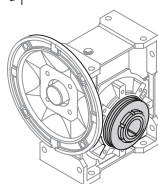

LD

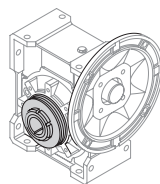

LS

Nella versione con limitatore non è prevista la fornitura degli alberi lenti.

The version with torque limiter is supplied without output shafts.

Die Version mit Drehmomentbegrenzer wird ohne Abtriebswellen geliefert.

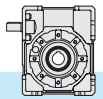

2.10 Accessori

2.10 Accessories

2.10 Accessories

Albero lento

Output shaft

Abtriebswelle

Albero lento semplice
Single output shaft
Standard Abtriebswelle

Albero lento doppio
Double output shaft
Doppelte Abtriebswelle

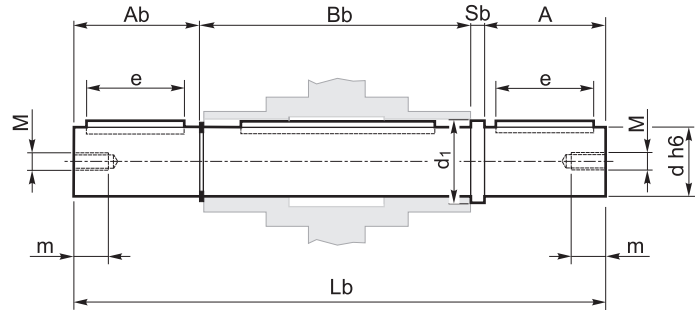
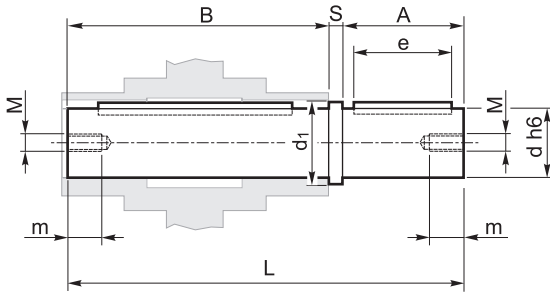

X	A	B	d _{h6}		d ₁	e	L	M	m	S
30	30	62	14		18.5	20	94.5	M6	16	2.5
40	40	77	18	19	23.5	30	120	M6	16	3
50	50	90	25	24	31.5	40	143.5	M8	22	3.5
63	50	111	25		31.5	40	165	M8	22	4
75	60	119	28	30	34.5	50	183	M8	22	4
90	80	139	35		41.5	60	224	M10	28	5
110	80	154.5	42		49.5	60	242.5	M10	28	8
130	80	168	45		54.5	70	253	M16	36	5

A	A _b	B _b	d _{h6}	d ₁	e	L _b	S _b
30	29	64	14	18.5	20	126	2.5
40	39	79	18	23.5	30	161	3
50	49	93	25	31.5	40	195.5	3.5
50	49	113	25	31.5	40	216	4
60	59	121	28	34.5	50	244	4
80	78.5	141.5	35	41.5	60	305	5
80	77.5	157	42	49.5	60	322.5	8
80	78	172	45	54.5	70	335	5

Braccio di reazione

Torque arm

Drehmomentstütze

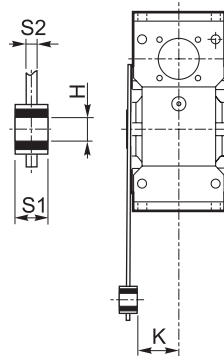
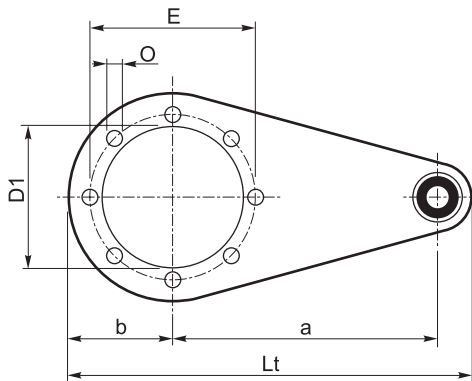

X	a	b	D ₁	E	H	K	L _t	O	S ₁	S ₂
30	85	37.5	55	65	8	24	141.5	7	14	4
40	100	45	60	75	10	31.5	167	7	14	4
50	100	50	70	85	10	39	172	9	14	5
63	150	55	80	95	10	49	227	9	14	6
75	200	70	95	115	20	47.5	302	9	25	6
90	200	80	110	130	20	57.5	312	11	25	6
110	250	100	130	165	25	62	390	11	30	6
130	250	125	180	215	25	69	415	13	30	6

Kit di protezione:

Protection Kit:

Schutzvorrichtung

Albero cavo / Hollow shaft / Hohlwelle

Limitatore di coppia / Torque limiter / Drehmomentbegrenzer

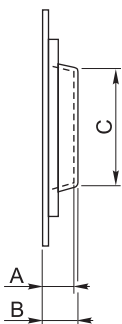

X	A	B	C
30	12	13	39
40	14	15.5	44.5
50	15	16.5	54
63	17	19	60
75	17.5	20	70
90	21.5	24	80
110	22	25	96
130	22	25	130

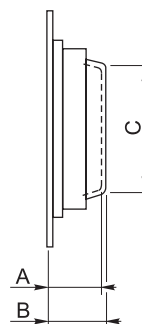

X	A	B	C
30	36	37	36
40	40	41.5	44
50	47	48.5	53
63	52	54	55
75	58	60	68
90	60.5	63	70
110	72	75	85
130			

Opzioni disponibili:

Available options:

Auf Anfrage ist folgendes Zubehör erhältlich:

Cuscinetti a rulli conici corona

Tapered roller bearing on wormgear

Kegelrollenlager auf Schneckenrad



XA - XF

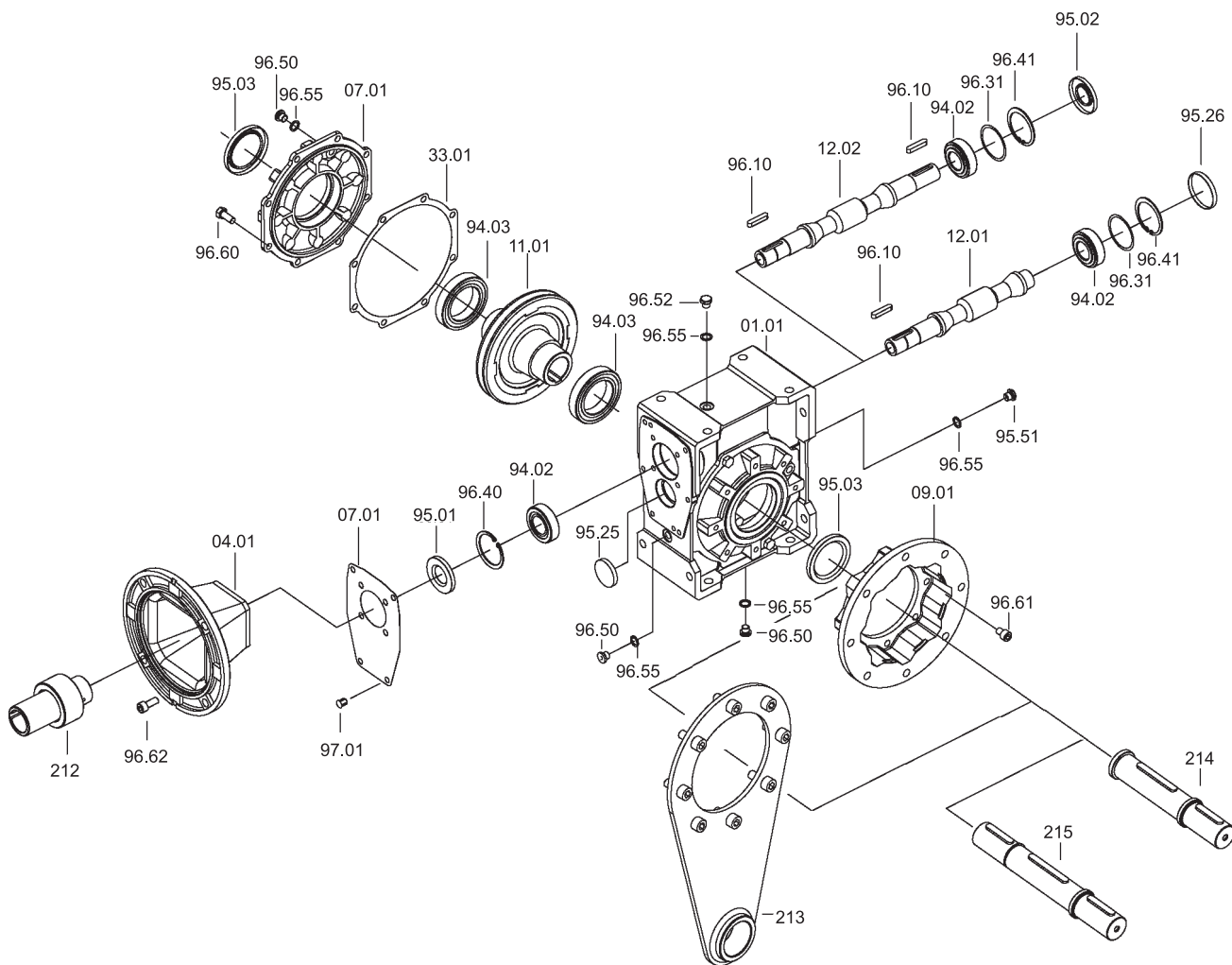

X	Cuscinetti / Bearings / Lager			Anelli di tenuta / Oilseals Öldichtungen			Cappellotto / Closed oil seal Geschlossene Öldichtung	
	94.02	94.03		95.01	95.02	95.03	95.25	95.26
30	6000 10x26x8	6005 25x47x12	*32005 25x47x15	10/26/5.5	10/26/7	25/40/7	—	ø 6x7
40	6201 12x32x10	6006 30x55x13	*32006 30x55x17	12/32/7	12/32/7	30/47/7	—	ø 32x7
50	6203 17x40x12	6008 40x68x15	*32008 40x68x19	17/40/7	17/40/7	40/62/8	—	ø 40x7
63	30204 20x47x15.25	6008 40x68x15	*32008 40x68x19	20/47/7	20/47/7	40/62/8	—	ø 47x7
75	30205 25x52x16.25	6010 50x80x16	*32010 50x80x20	25/52/7	25/52/7	50/72/8	—	ø 52x7
90	32205 25x52x19.25	6010 50x80x16	*32010 50x80x20	25/52/7	25/52/7	50/72/8	ø 35x5	ø 52x7
110	32206B 30x62x21.25	6012 60x95x18	*32012 60x95x23	30/62/7	30/62/7	60/85/8	ø 47x7	ø 62x7
130	33208 40x80x32	6015 75x115x20	*32015 75x115x25	40/80/10	40/80/10	75/100/10	ø 52x7	ø 80x10

* Cuscinetti a rulli conici a richiesta - Tapered roller bearings on request - Auf Wunsch Kegelrollenlager



XC

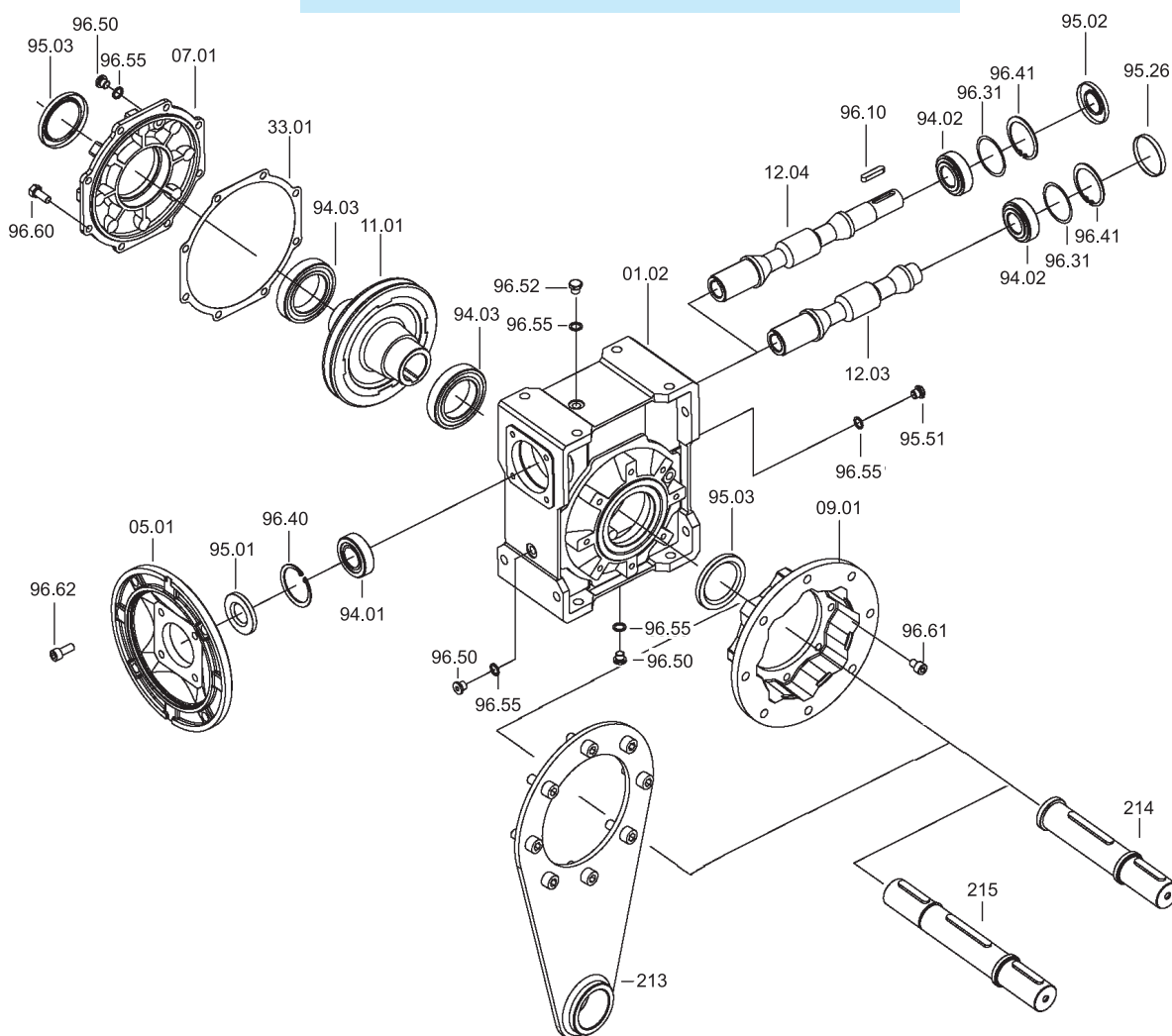

X	IEC	Cuscinetti / Bearings / Lager				Anelli di tenuta / Oilseals Öldichtungen			Cappello / Closed oil seal Geschlossene Öldichtung
		94.01	94.02	94.03		95.01	95.02	95.03	95.26
30	56	61804 (20x32x7)	6000 10x26x8	6005 25x47x12	*32005 25x47x15	20/32/5	10/26/7	25/40/7	ø 26x7
	63	61804 (20x32x7)		20/32/5					
40	56	6303 (17x47x14)	6201 12x32x10	6006 30x55x13	*32006 30x55x17	17/47/7	12/32/7	30/47/7	ø 32x7
	63	6204 (20x47x14)		20/47/7					
	71	6005 (25x47x12)		25/47/7					
50	63	6204 (20x47x14)	6203 17x40x12	6008 40x68x15	*32008 40x68x19	20/47/7	17/40/7	40/62/8	ø 40x7
	71	6005 (25x47x12)		25/47/7					
	80	6006 (30x55x13)		30/55/7					
63	71	30305 (25x62x18.25)	30204 20x47x15.25	6008 40x68x15	*32008 40x68x19	25/62/7	20/47/7	40/62/8	ø 47x7
	80	30206 (30x62x17.25)		30/62/7					
	90	32007 (35x62x18)		35/62/7					
75	80	30206 (30x62x17.25)	30205 25x52x16.25	6010 50x80x16	*32010 50x80x20	30/62/7	25/52/7	50/72/8	ø 52x7
	90	32007 (35x62x18)		35/62/7					
	100/112	32008 (40x68x19)		40/68/10					
90	80	30206 (30x62x17.25)	32205B 25x52x19.25	6010 50x80x16	*32010 50x80x20	30/62/7	25/52/7	50/72/8	ø 52x7
	90	32007 (35x62x18)		35/62/7					
	100/112	32008 (40x68x19)		40/68/10					
110	90	30208 (40x80x19.75)	32206B 30x62x21.25	6012 60x95x18	*32012 60x95x23	40/80/10	30/62/7	60/85/8	ø 62x7
	100/112	30208 (40x80x19.75)		40/80/10					
	132	32010 (50x80x20)		50/80/10					
130	90	30208 (40x80x19.75)	33208 40x80x32	6015 75x115x20	*32015 75x115x25	40/80/10	40/80/10	75/100/10	ø 80x10
	100/112	30208 (40x80x19.75)		40/80/10					
	132	32010 (50x80x20)		50/80/10					

* Cuscinetti a rulli conici a richiesta - Tapered roller bearings on request - Auf Wunsch Kegelrollenlager

