

Input data

System of measurement		Metric
Input type		Gear motor
Input speed	[rpm]	1400
Output speed	[rpm]	93.33
Ratio (i=)		15
Frequency	[Hz]	50
Input options		IEC
Requested input power	[kW]	1.5
Service factor		1.5
Rated Power P1	[kW]	2.21

Output data

Gear unit M RT 70 B3 15 90 B14 AC 28 MT 1.5 kW 90 L4 B14 X3

Type		RT - Worm speed reducers
Input type		M
Size		70
Ratio (i=)		15
Input flange		B14
Input speed	[rpm]	1400
Output speed	[rpm]	93.33
Rated output torque	[Nm]	127.39
Service Factor		1.5
Efficiency		0.83
Inertia moment	[kgm ²]	0.000257

Gear unit configuration

Output shaft		Hollow output shaft
Fixing		Universal
Version		B3

Output radial and axial loads

Ball bearings output radial load	[N]	3600
Taper bearings output radial load	[N]	4500
Ball bearings output axial load	[N]	720
Taper bearings output axial load	[N]	900

Accessories

Hollow output shaft		AC 28
---------------------	--	-------

Electric motor

Size		90 L4
Poles		4
Power	[kW]	1.5

Electric motor configuration

Motor flange		B14
Terminal box position		X3

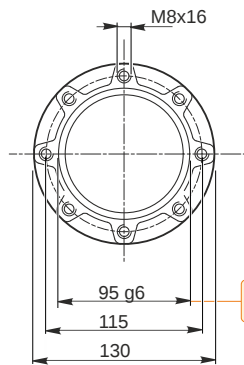
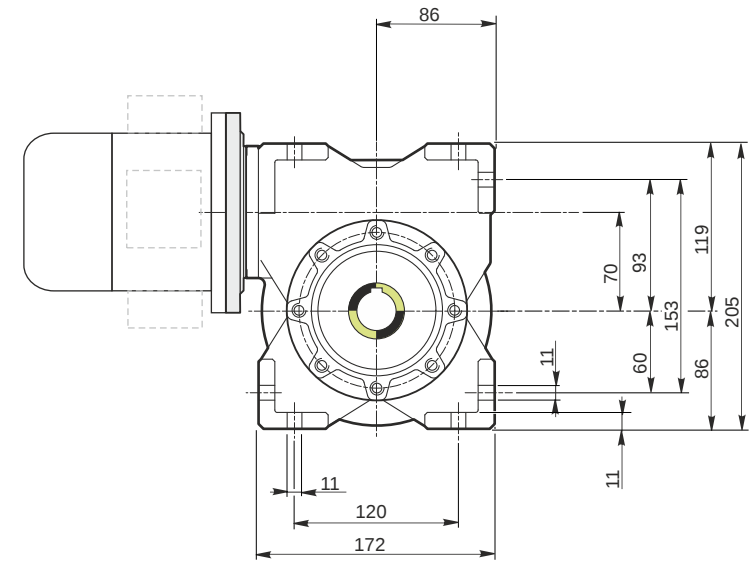
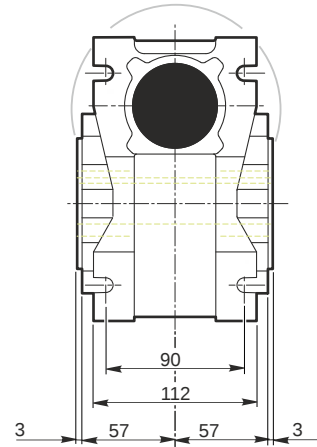
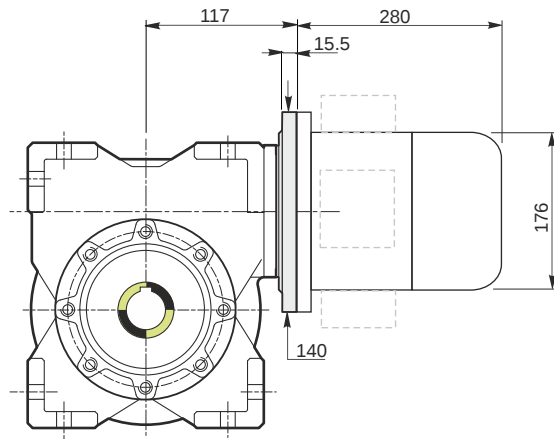

Hollow output shaft

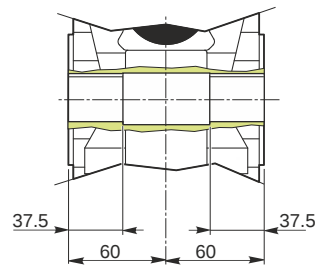
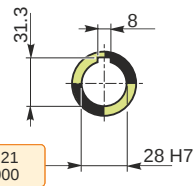

Mounting positions

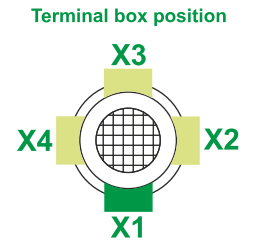
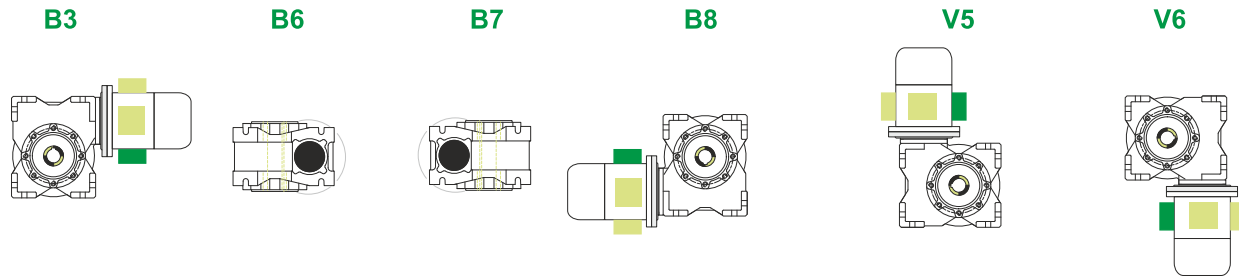

0.35



← Oil quantity [litres]

Lubricant type: Long life synthetic oil ISO VG320

Direction of rotation

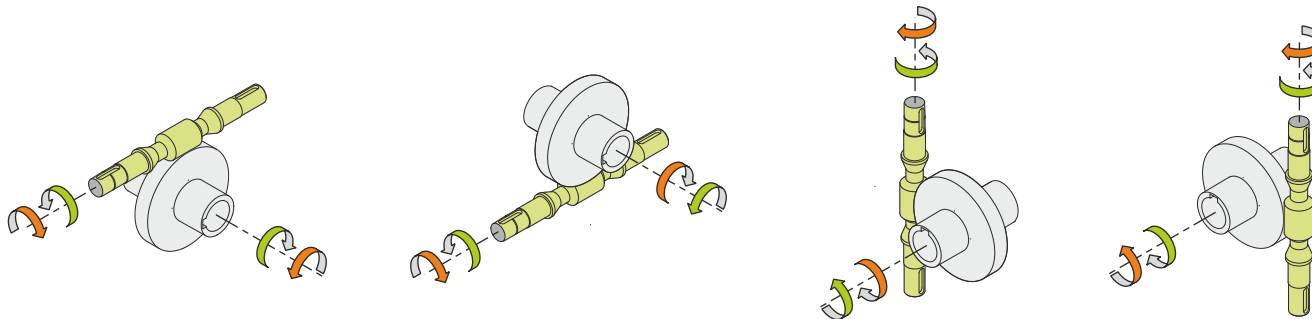

Weight

Gear unit [kg]	9
Electric motor [kg]	13.5

Gearing data

Axial module	3.6
Number of starts	2
Lead angle	12° 40'
Pressure angle	20°

Backdriving

- Static back-driving
- Quick back-driving
- Dynamic back-driving

M RT 70 B3 15 90 B14 AC 28 MT 1.5 kW 90 L4 B14 X3