

Input data

| | | |
|-----------------------|-------|------------|
| System of measurement | | Metric |
| Input type | | Gear motor |
| Input speed | [rpm] | 1400 |
| Output speed | [rpm] | 28.57 |
| Ratio (i=) | | 49 |
| Frequency | [Hz] | 50 |
| Input options | | IEC |
| Requested input power | [kW] | 0.55 |
| Service factor | | 1.1 |
| Rated Power P1 | [kW] | 0.62 |

Output data

Gear unit **M RT 60 B3 49 80 B14 AC 25 MT 0.55 kW 80 A4 B14 X3**

| | | |
|---------------------|---------------------|--------------------------|
| Type | | RT - Worm speed reducers |
| Input type | | M |
| Size | | 60 |
| Ratio (i=) | | 49 |
| Input flange | | B14 |
| Input speed | [rpm] | 1400 |
| Output speed | [rpm] | 28.57 |
| Rated output torque | [Nm] | 113.98 |
| Service Factor | | 1.1 |
| Efficiency | | 0.62 |
| Inertia moment | [kgm ²] | 0.000104 |

Gear unit configuration

| | | |
|--------------|--|---------------------|
| Output shaft | | Hollow output shaft |
| Fixing | | Universal |
| Version | | B3 |

Output radial and axial loads

| | | |
|-----------------------------------|-----|------|
| Ball bearings output radial load | [N] | 4300 |
| Taper bearings output radial load | [N] | 5700 |
| Ball bearings output axial load | [N] | 860 |
| Taper bearings output axial load | [N] | 1140 |

Accessories

| | | |
|---------------------|--|-------|
| Hollow output shaft | | AC 25 |
|---------------------|--|-------|

Electric motor

| | | |
|-------|------|-------|
| Size | | 80 A4 |
| Poles | | 4 |
| Power | [kW] | 0.55 |

Electric motor configuration

| | | |
|-----------------------|--|-----|
| Motor flange | | B14 |
| Terminal box position | | X3 |

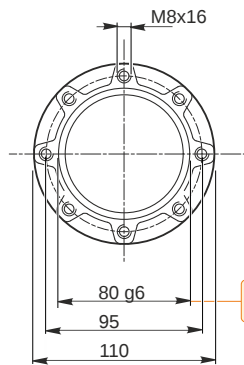
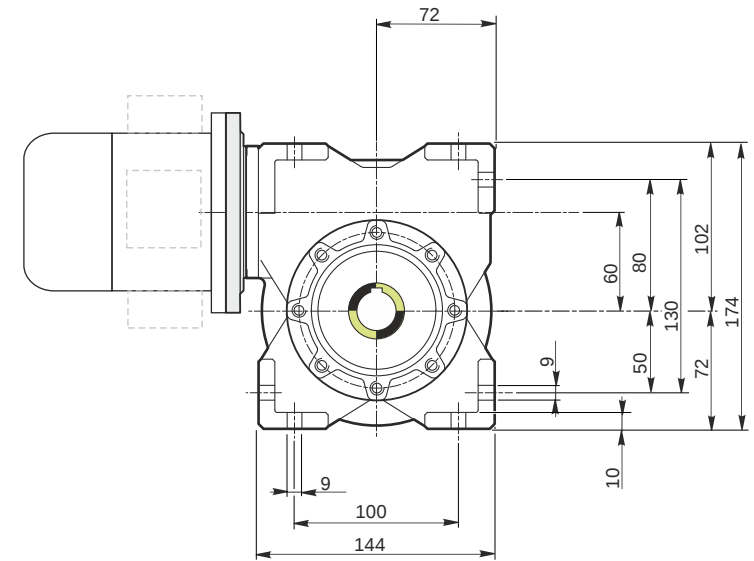
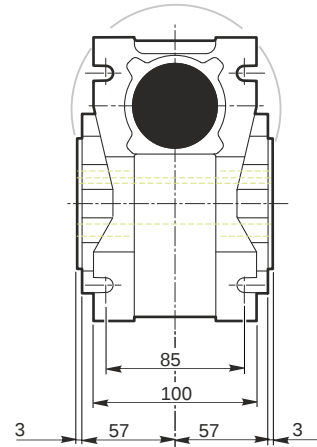
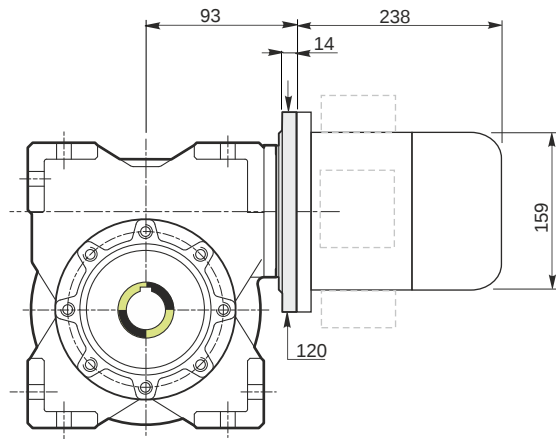

Hollow output shaft

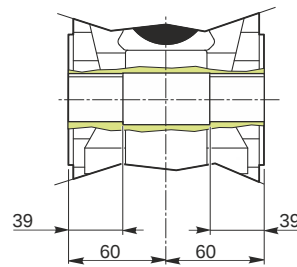
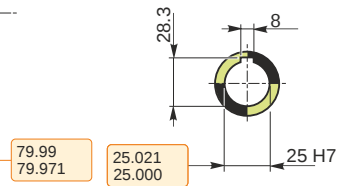

Mounting positions

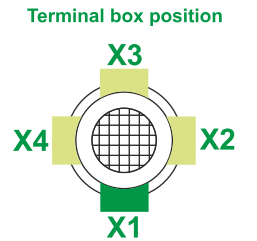
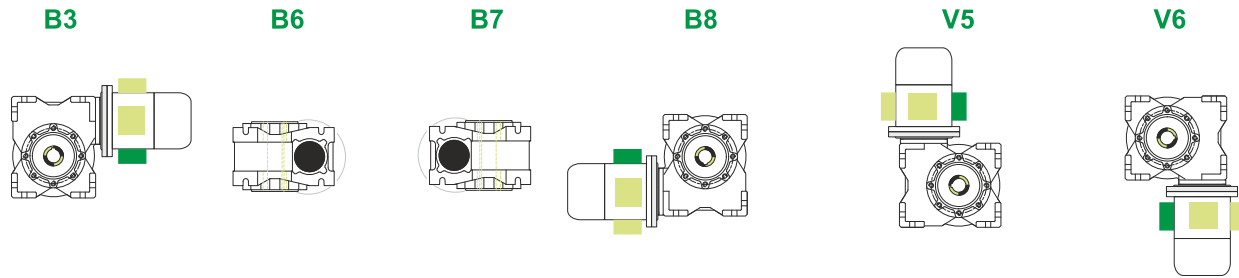

0.23



← Oil quantity [litres]

Lubricant type: Long life synthetic oil ISO VG320

Direction of rotation

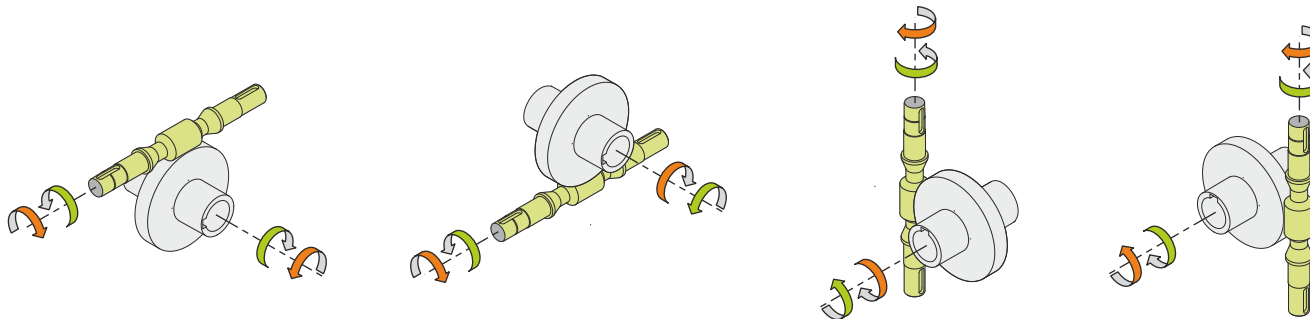

Weight

| | |
|---------------------|-----|
| Gear unit [kg] | 6.5 |
| Electric motor [kg] | 9.8 |

Gearing data

| | |
|------------------|--------|
| Axial module | 2 |
| Number of starts | 1 |
| Lead angle | 5° 11' |
| Pressure angle | 20° |

Backdriving

Static self-locking
Slow back-driving in case of vibrations
Low dynamic back-driving

M RT 60 B3 49 80 B14 AC 25 MT 0.55 kW 80 A4 B14 X3