

### Input data

System of measurement		Metric
Input type		Gear motor
Input speed	[rpm]	1400
Output speed	[rpm]	70
Ratio (i=)		20
Frequency	[Hz]	50
Input options		IEC
Requested input power	[kW]	0.13
Service factor		1.2
Rated Power P1	[kW]	0.16

### Output data

**Gear unit** **M RT 28 B3 20 63 B14 AC 14 MT 0.13 kW 63 A4 B14 X3**

Type		RT - Worm speed reducers
Input type		M
Size		28
Ratio (i=)		20
Input flange		B14
Input speed	[rpm]	1400
Output speed	[rpm]	70
Rated output torque	[Nm]	13.12
Service Factor		1.2
Efficiency		0.74
Inertia moment	[kgm <sup>2</sup> ]	0.000005

#### Gear unit configuration

Output shaft		Hollow output shaft
Fixing		Universal
Version		B3

#### Output radial and axial loads

Ball bearings output radial load	[N]	600
Taper bearings output radial load	[N]	900
Ball bearings output axial load	[N]	120
Taper bearings output axial load	[N]	180

#### Accessories

Hollow output shaft		AC 14
---------------------	--	-------

#### Electric motor

Size		63 A4
Poles		4
Power	[kW]	0.13

#### Electric motor configuration

Motor flange		B14
Terminal box position		X3

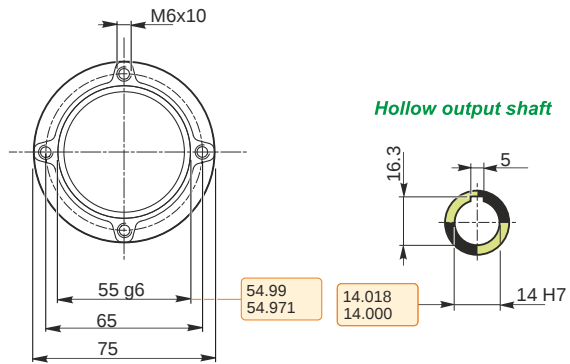
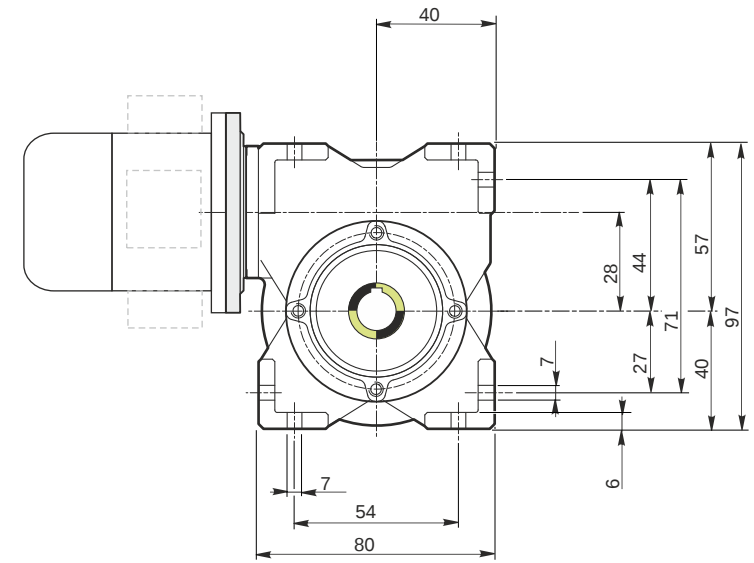
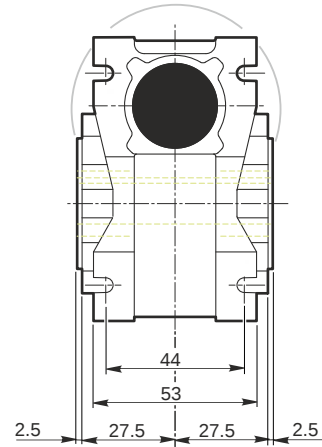
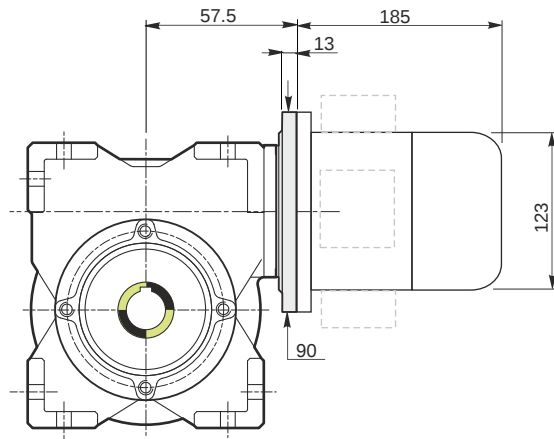

*Hollow output shaft*

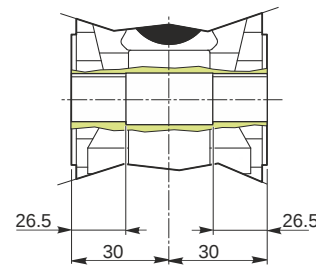

**Mounting positions**

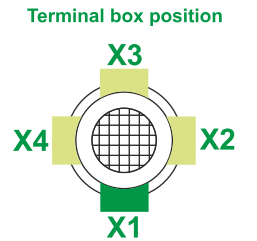
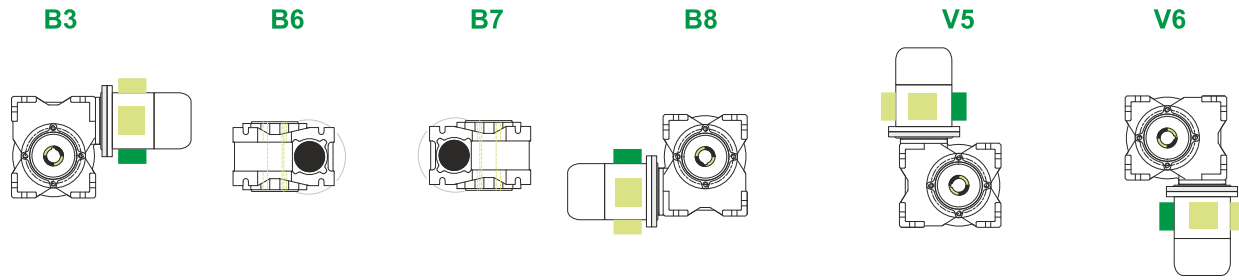

0.03



← Oil quantity [litres]

Lubricant type: Long life synthetic oil ISO VG320

**Direction of rotation**

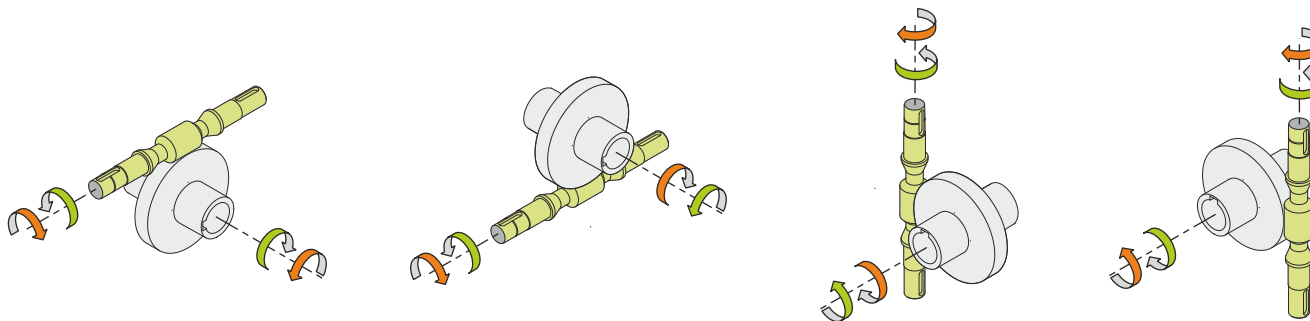

**Weight**

Gear unit [kg]	1.1
Electric motor [kg]	4.3

**Gearing data**

Axial module	1.1
Number of starts	2
Lead angle	10° 23'
Pressure angle	20°

**Backdriving**

Variable static self-locking  
Quick back-driving in case of vibrations  
Dynamic back-driving

**M RT 28 B3 20 63 B14 AC 14 MT 0.13 kW 63 A4 B14 X3**